

HOME REFRIGERATORS

SERVICE MANUAL

2011

NO.SM-RE-1126

Models MR-C375C-W-A
MR-C375C-ST-A
MR-C375CL-W-A
MR-C375CL-ST-A
MR-C405C-W-A
MR-C405C-ST-A
MR-C405CL-W-A
MR-C405CL-ST-A

CONTENTS

1. SPECIFICATIONS.....	1
2. OUTLINES AND DIMENSIONS.....	3
3. WIRING DIAGRAM.....	5
4. REFRIGERANT CIRCUIT.....	7
5. NAMES OF THE PARTS.....	9
6. TROUBLE SHOOTING.....	11
6.1 TROUBLE CRITERION OF MAIN PARTS.....	11
6.2 FUNCTION OF OPERATION PANEL.....	14
6.3 FLOW CHART OF SELF-CHECK.....	15
6.4 TEST POINT DIAGRAM OF MAIN CONTROL BOARD.....	18
7. DISASSEMBLY INSTRUCTIONS.....	19
8. PARTS LIST.....	24

1

SPECIFICATIONS

1-1 SPECIFICATIONS

MR-C375C-A, MR-C375CL-A

Power supply		230-240V 50Hz	
Total capacity	L	GROSS (AS) 375 (R : 197 V : 75 F : 103)	
Dimensions (HXWXD)	mm.	1678 x 600 x 656	
Cabinet		Acrylic resin coated steel	
Food liner		ABS resin	
Insulation	Cabinet	Foamed cyclopentane	
	Refrigerator door	Foamed cyclopentane	
	Vegetable door	Foamed cyclopentane	
	Freezer door	Foamed cyclopentane	
Cooling system	Freezer	Forced air convection	
	Refrigerator	3 way air flow	
Evaporator		Fin and tube type	
Condenser		Concealed type	
Defrost system		Automatic (Defrost heater)	
Drain		Automatic (drainage)	
Temperature control system		Automatic control	
Refrigerator room light		240V, 15W (E12)	
Accessories	Glass shelf (R)	1 pc.	
	Slide shelf	1 pc.	
	Slide chilled case	1 pc.	
	Water tank	1 pc.	
	Free pocket (L)	2 pcs.	
	Egg case	1 pc.	
	Bottle pocket	1 pc.	
	Vegetable case	1 pc.	
	Fruit case	1 pc.	
	Freezing case (UP)	1 pc.	
	Freezing case (LOW)	1 pc.	
	Ice box sheet	1 pc.	
	Ice spoon	1 pc.	
	Ice box	1 pc.	
	Kick plate	1 pc.	
Weight	Unit	kg	69
	Shipping	kg	75

MR-C405C-A, MR-C405CL-A

Power supply		230-240V 50Hz	
Total capacity	L	GROSS (AS) 405 (R : 227 V : 75 F : 103)	
Dimensions (HXWXD)	mm.	1798 x 600 x 656	
Cabinet		Acrylic resin coated steel	
Food liner		ABS resin	
Insulation	Cabinet	Foamed cyclopentane	
	Refrigerator door	Foamed cyclopentane	
	Vegetable door	Foamed cyclopentane	
	Freezer door	Foamed cyclopentane	
Cooling system	Freezer	Forced air convection	
	Refrigerator	3 way air flow	
Evaporator		Fin and tube type	
Condenser		Concealed type	
Defrost system		Automatic (Defrost heater)	
Drain		Automatic (drainage)	
Temperature control system		Automatic control	
Refrigerator room light		240V, 15W (E12)	
Accessories	Glass shelf (R)		2 pcs.
	Slide shelf		1 pc.
	Slide chilled case		1 pc.
	Water tank		1 pc.
	Free pocket (L)		2 pcs.
	Egg case		1 pc.
	Free pocket (S)		1 pc.
	Bottle pocket		1 pc.
	Vegetable case		1 pc.
	Fruit case		1 pc.
	Freezing case (UP)		1 pc.
	Freezing case (LOW)		1 pc.
	Ice box sheet		1 pc.
	Ice spoon		1 pc.
	Ice box		1 pc.
Kick plate		1 pc.	
Weight	Unit	kg	73
	Shipping	kg	80

1-2 ELECTRICAL PARTS SPECIFICATION

MR-C375C-A , MR-C375CL-A

Compressor	Model		DHS66C10RAW			
	Power supply		220-240V, 50Hz			
	Rated input	W	113/113.5(220/240V 50Hz)			
	Starting current	A	7.78/8.55(220/240V 50Hz)			
	Rated current	A	0.70/0.64(220/240V 50Hz)			
	Winding resistance (A.T. 20 °C)		18.4 Ω(Main) / 18.5 Ω(Aux)			
PTC RELAY			PTH7M330MD2			
Motor protector	Model		5TM718MFBYY-53			
	Ambient temperature	°C	25			
	Time	Sec.	16 MAX			
	Current	A	4.2			
Running capacitor			4μF 400VAC			
Capillary tube		mm.	∅ 1.8 X ∅ 0.6 X 2350			
Dehydrant Molecular sieve		g	10			
Refrigerant HFC. 134a		g	170			
Defrosting control	Defrosting timer		Control board			
	Defrost finish	°C	Thermister 14 ± 1.5			
	Thermal fuse	°C	73			
	Defrost heater		372 Ω (240V, 155W)			
	Deodorizing function of defrost heater		Not equipped			
Fan motor	Refrigerator	Model		FBA12J12VXC		
		Type		DC brushless		
		Rate Voltage		12 VDC		
		Input	W	4.2 (12 VDC)		
		Revolution	r.p.m	2300 (12 VDC)		
	Machine Chamber	Model		4715JL04WS16G51		
		Type		DC brushless		
		Rate Voltage		12 VDC		
		Input	W	1.44 (12 VDC)		
		Revolution	r.p.m	1450 (12 VDC)		
Heater	Vegetable case heater		W	6		
	Water pipe heater		W	0.9		
	Drain pipe heater		W	6		
Temperature control			Thermistor F		Thermistor R	
			Freezer		Refrigerator	
	Dial position		ON	OFF	OPEN	SHUT
	LOW	°C	-9.2	-15.7	7.0	5.1
	MID	°C	-14.0	-20.0	4.2	2.3
HI	°C	-16.0	-21.9	1.6	-0.2	

MR-C405C-A, MR-C405CL-A

Compressor	Model		DHS66C10RAW			
	Power supply		220-240V, 50Hz			
	Rated input	W	113/113.5(220/240V 50Hz)			
	Starting current	A	7.78/8.55(220/240V 50Hz)			
	Rated current	A	0.70/0.64(220/240V 50Hz)			
	Winding resistance (A.T. 20 °C)		18.4 Ω(Main) / 18.5 Ω(Aux)			
PTC RELAY			PTH7M330MD2			
Motor protector	Model		5TM718MFBYY-53			
	Ambient temperature	°C	25			
	Time	Sec.	16 MAX			
	Current	A	4.2			
Running capacitor			4μF 400VAC			
Capillary tube	mm.	∅ 1.8 X ∅ 0.6 X 2350				
Dehydrant Molecular sieve	g	10				
Refrigerant HFC. 134a	g	170				
Defrosting control	Defrosting timer		Control board			
	Defrost finish	°C	Thermister 14 ± 1.5			
	Thermal fuse	°C	73			
	Defrost heater		372 Ω (240V, 155W)			
	Deodorizing function of defrost heater		Not equipped			
Fan motor	Refrigerator	Model		FBA12J12VXC		
		Type		DC brushless		
		Rate Voltage		12 VDC		
		Input	W	4.2 (12 VDC)		
		Revolution	r.p.m	2300 (12 VDC)		
	Machine Chamber	Model		4715JL04WS16G51		
		Type		DC brushless		
		Rate Voltage		12 VDC		
		Input	W	1.44 (12 VDC)		
		Revolution	r.p.m	1450 (12 VDC)		
Heater	Vegetable case heater	W	6			
	Water pipe heater	W	0.9			
	Drain pipe heater	W	6			
Temperature control			Thermistor F		Thermistor R	
			Freezer		Refrigerator	
	Dial position		ON	OFF	OPEN	SHUT
	LOW	°C	-9.2	-15.7	7.4	5.4
	MID	°C	-14.0	-20.0	4.5	2.6
HI	°C	-16.0	-21.9	1.9	0.1	

2

OUTLINES AND DIMENSIONS

Unit : mm

MR-C375C-A, MR-C375CL-A

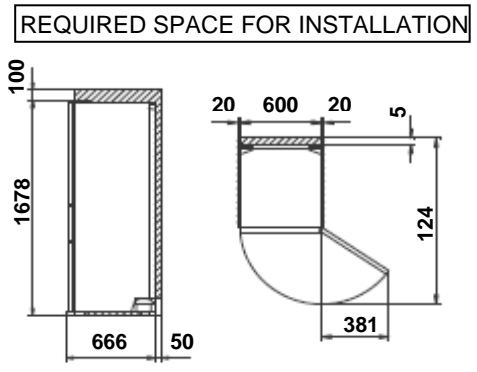
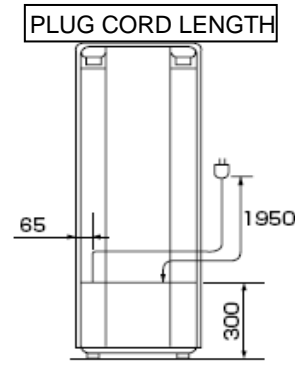
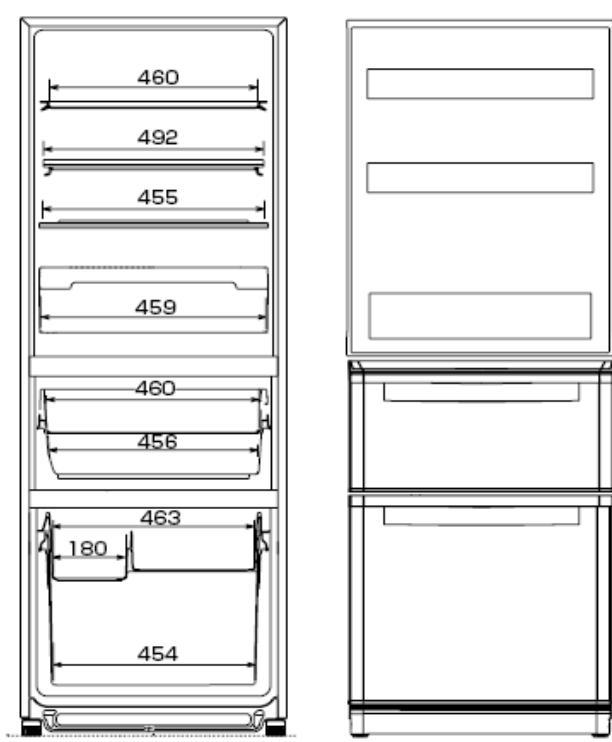
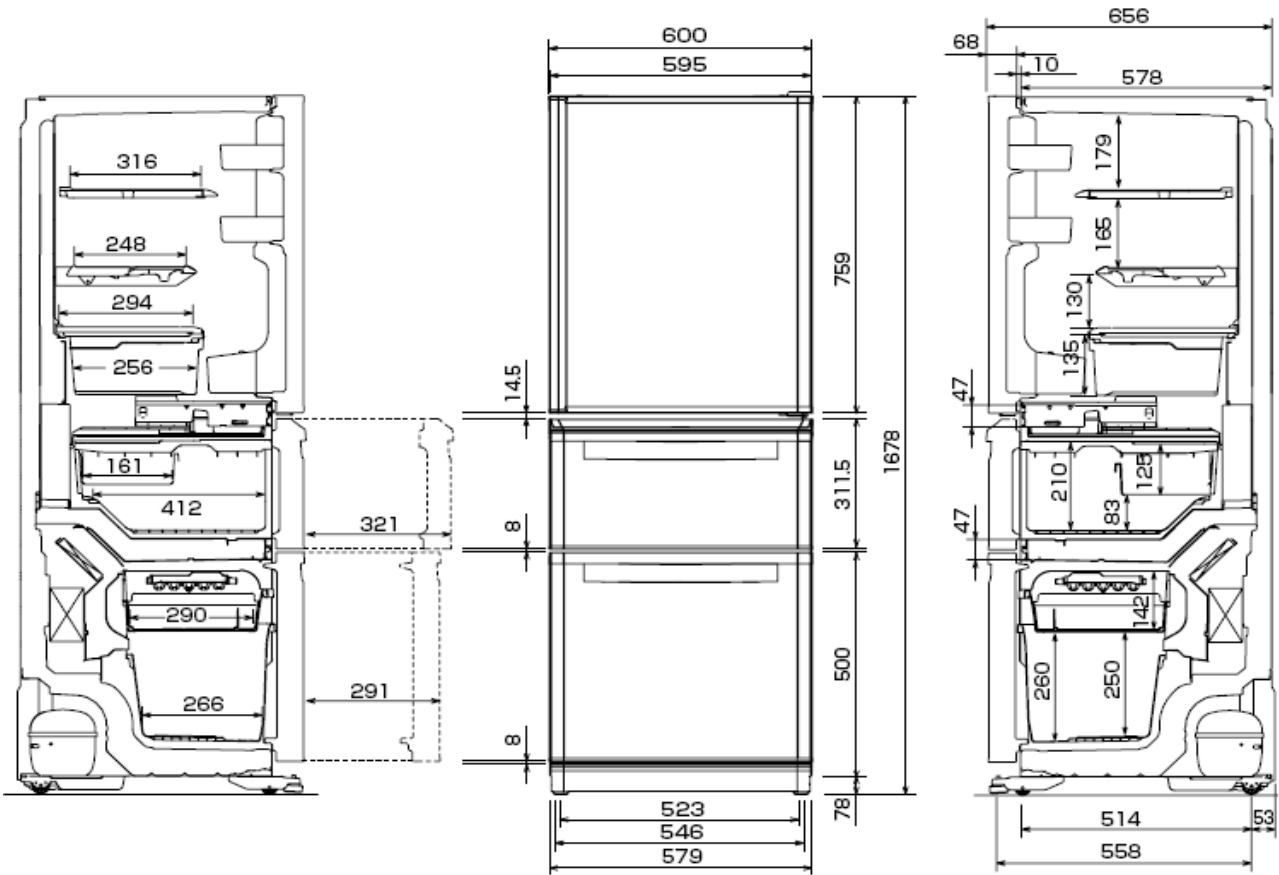

Unit : mm

MR-C405C-A, MR-C405CL-A

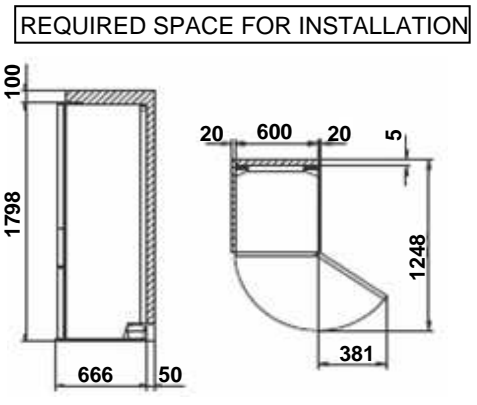
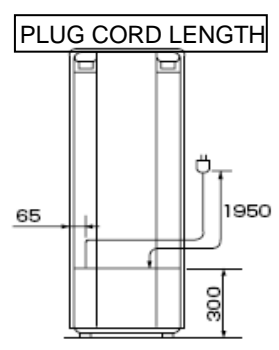
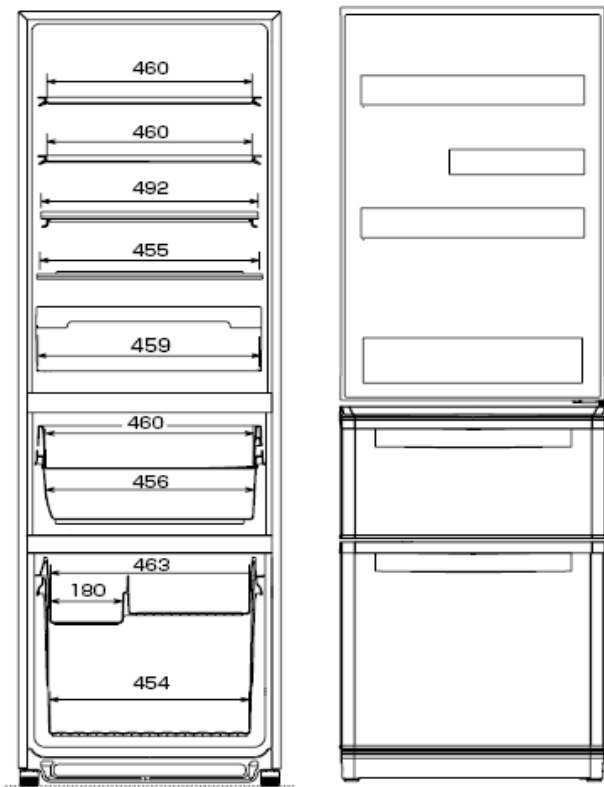
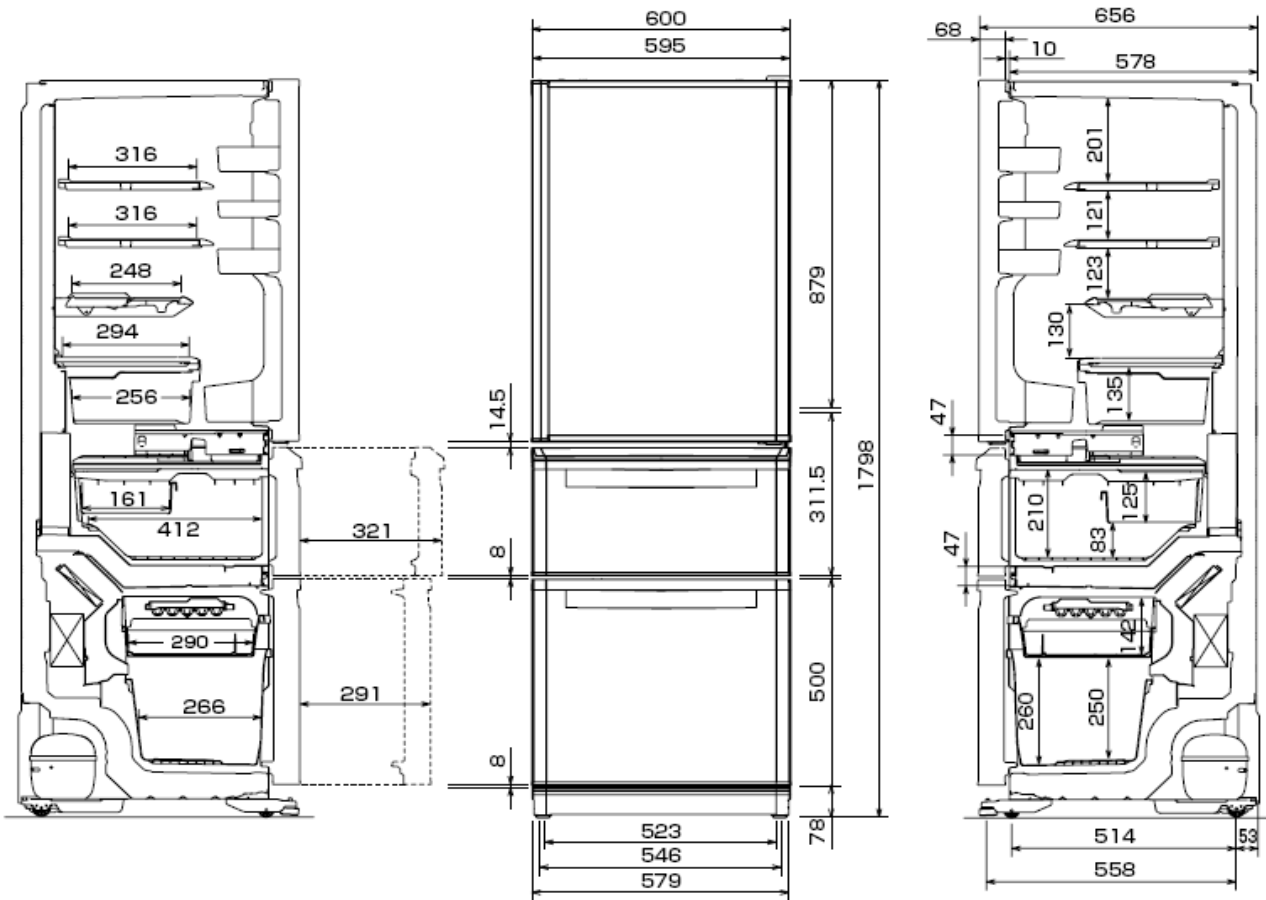

(ACTUAL WIRING DIAGRAM)

MR-C375C-A, MR-C375CL-A

MR-C405C-A, MR-C405CL-A

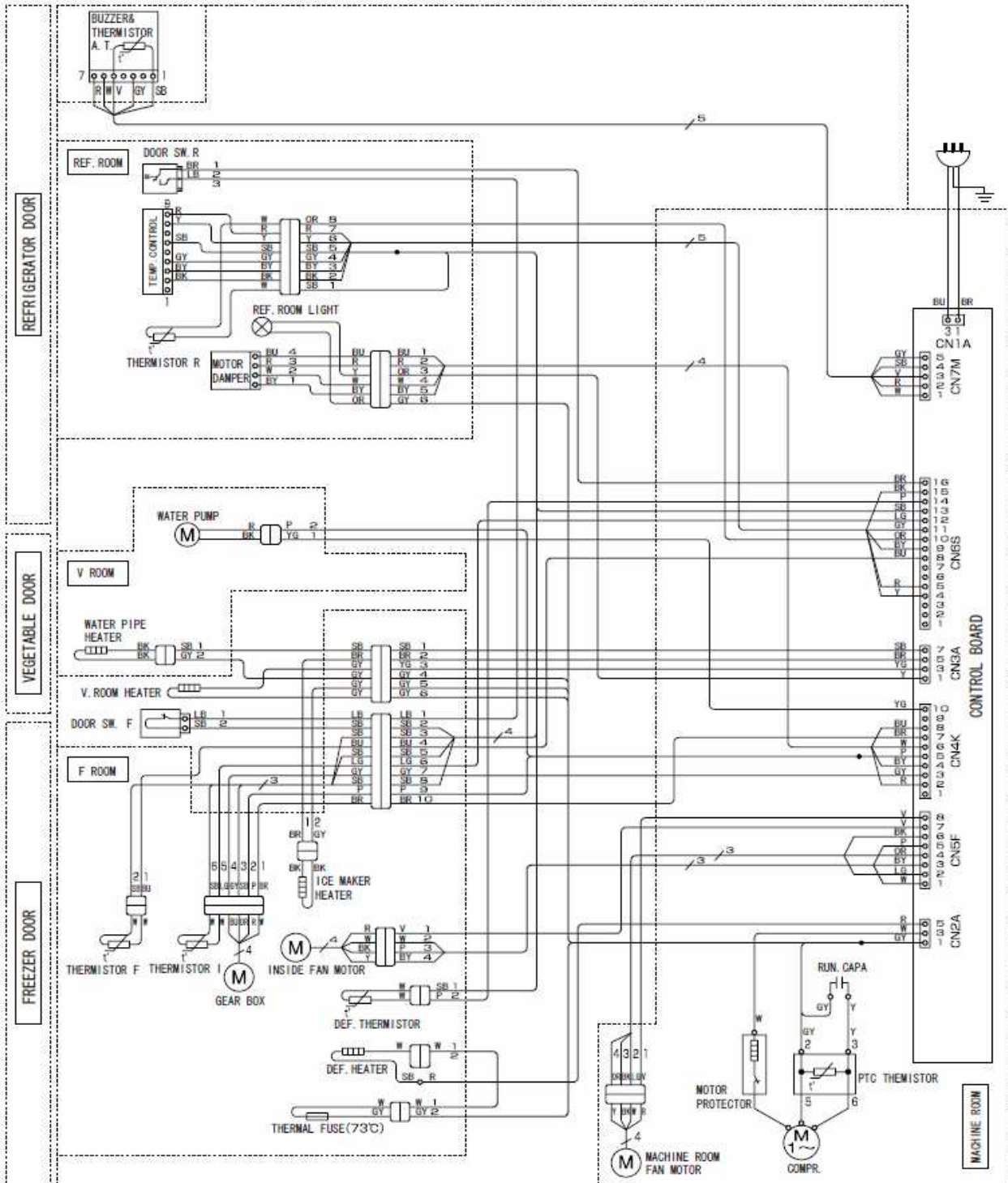

Remark	GY = GRAY	BK = BLACK	BR = BROWN
	W = WHITE	OR = ORANGE	
	R = RED	Y = YELLOW	
	SB = SKY BLUE	YG = YELLOW/GREEN	
	P = PINK	LG = LIGHT GREEN	
	LB = LIGHT BROWN	BY = BRIGHT YELLOW	
	V = VIOLET	BU = BLUE	

4

REFRIGERANT CIRCUIT

MR-C375C-A, MR-C375CL-A

MR-C405C-A, MR-C405CL-A

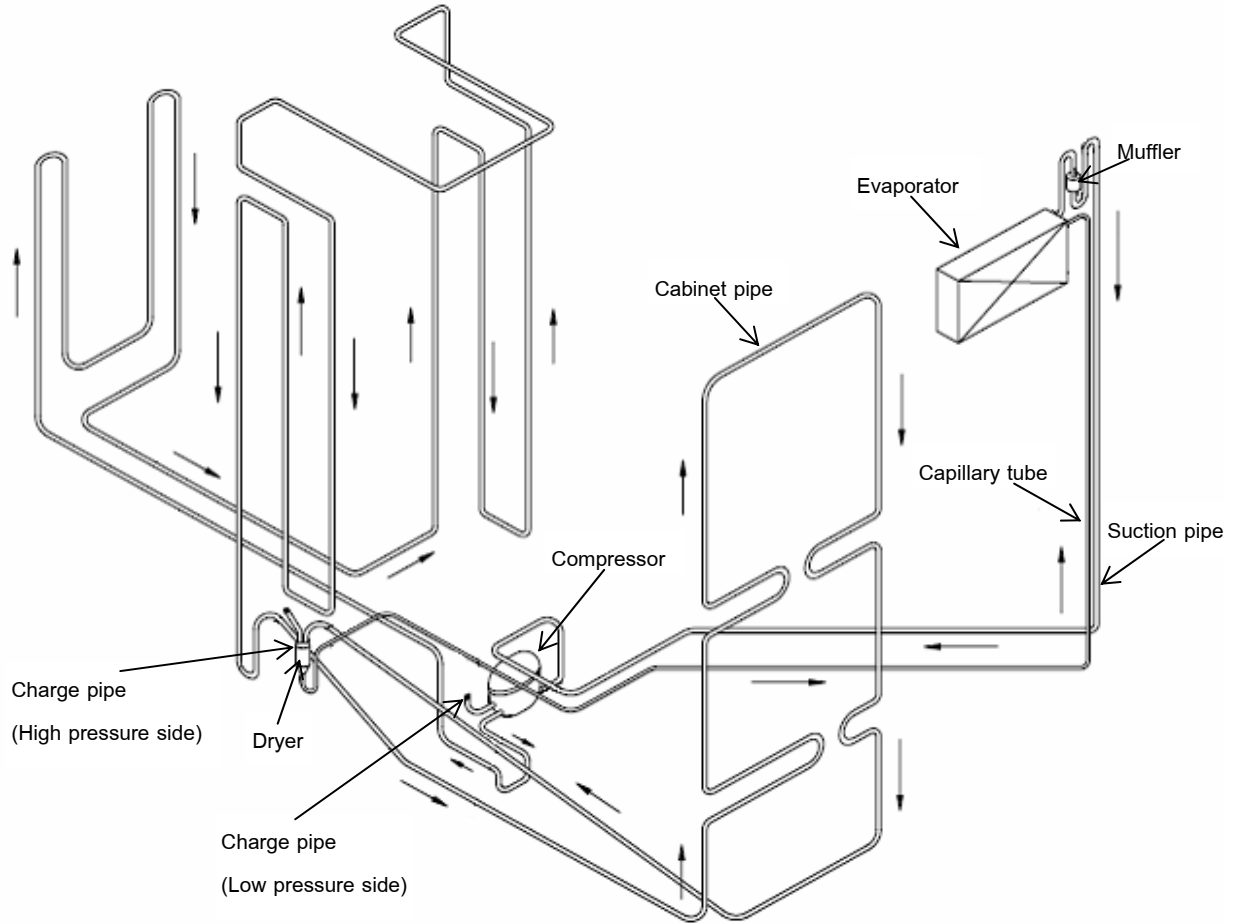

MR-C375C-A MR-C375CL-A MR-C405C-A MR-C405CL-A

Refrigerator Compartment

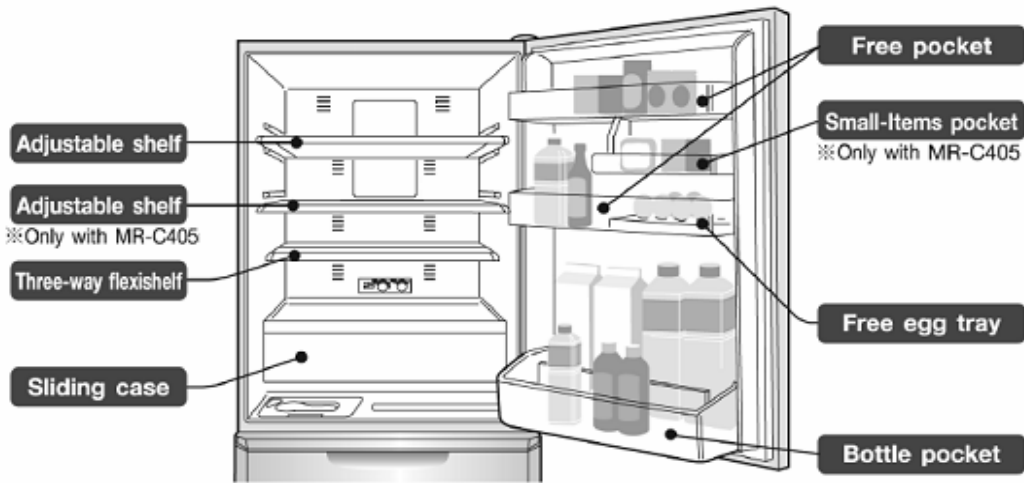

Automatic Ice-Maker

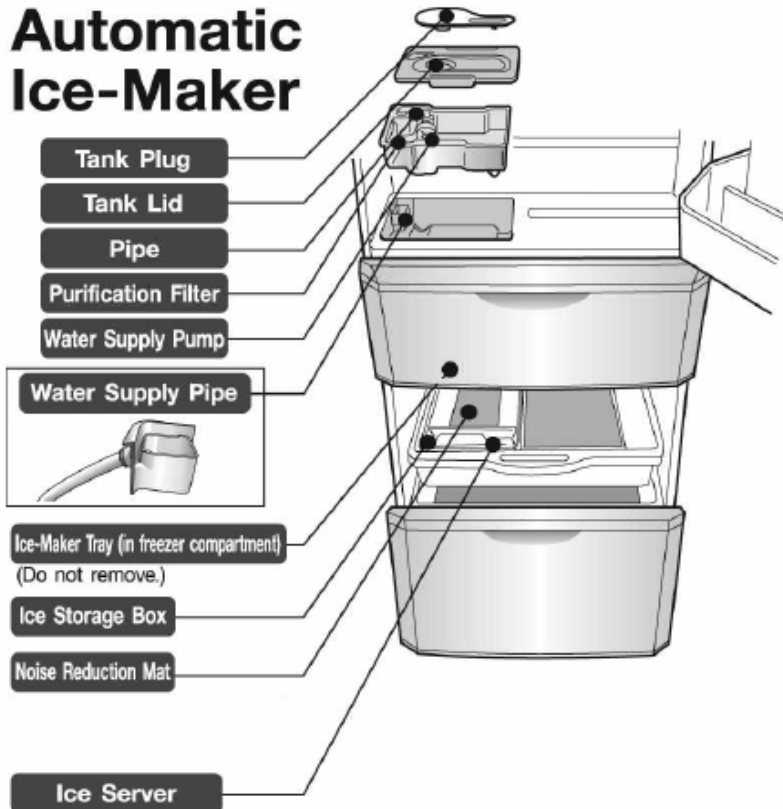

Freezer Compartment

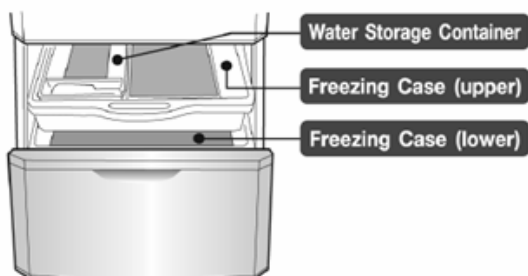

Vegetable Compartment

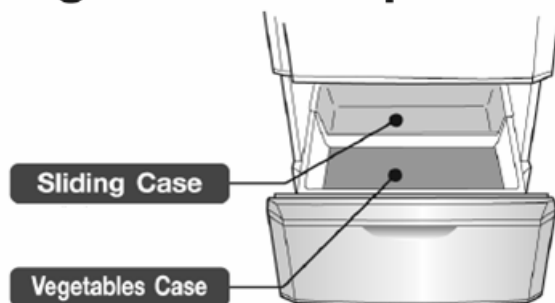

6

TROUBLE SHOOTING

6.1 TROUBLE CRITERION OF MAIN PARTS

MR-C375CC-A MR-C375CL-A MR-C405C-A MR-C405CL-A

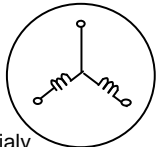
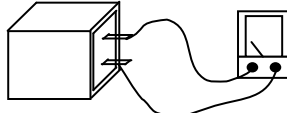
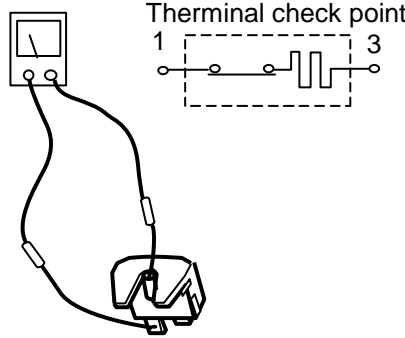
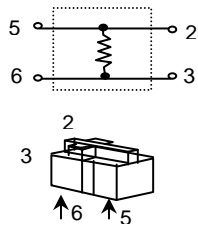
Components / Part Name	Check Method and Criterion	Parts Mounted Position																									
Compressor	<table border="1" style="margin-bottom: 10px;"> <tr> <td colspan="2">Model</td> <td colspan="2">DHS66C10RAW</td> </tr> <tr> <td>Rated input</td> <td>W</td> <td colspan="2">113/113.5(220/240V 50Hz)</td> </tr> <tr> <td>Starting current</td> <td>A</td> <td colspan="2">7.78./8.55(220/240V 50Hz)</td> </tr> <tr> <td>Rated current</td> <td>A</td> <td colspan="2">0.70/0.64(220/240V 50Hz)</td> </tr> </table> <table border="1" style="margin-bottom: 10px;"> <tr> <td></td> <td>Normal</td> <td>Abnormal (faulty)</td> </tr> <tr> <td>Main wiring</td> <td>18.4 Ω (Approx.)</td> <td>Opened (∞ Ω) or Short (0Ω)</td> </tr> <tr> <td>Auxilliary wiring</td> <td>18.5 Ω (Approx.)</td> <td></td> </tr> </table>  <p>Auxiliary wiring Main wiring</p> <p>Measure the resistance with a tester. (Ambient temperature: Room temperature 15°C ~ 25°C)</p>	Model		DHS66C10RAW		Rated input	W	113/113.5(220/240V 50Hz)		Starting current	A	7.78./8.55(220/240V 50Hz)		Rated current	A	0.70/0.64(220/240V 50Hz)			Normal	Abnormal (faulty)	Main wiring	18.4 Ω (Approx.)	Opened (∞ Ω) or Short (0Ω)	Auxilliary wiring	18.5 Ω (Approx.)		Compressor in the machine chamber at the rear side of the frame
Model		DHS66C10RAW																									
Rated input	W	113/113.5(220/240V 50Hz)																									
Starting current	A	7.78./8.55(220/240V 50Hz)																									
Rated current	A	0.70/0.64(220/240V 50Hz)																									
	Normal	Abnormal (faulty)																									
Main wiring	18.4 Ω (Approx.)	Opened (∞ Ω) or Short (0Ω)																									
Auxilliary wiring	18.5 Ω (Approx.)																										
Run capacitor	 <table border="1" style="margin-bottom: 10px;"> <tr> <td>Rated input</td> <td>400VAC</td> </tr> </table> <p>Measure the resistance with a tester.</p> <table border="1"> <tr> <td>Normal</td> <td>Abnormal(faulty)</td> </tr> <tr> <td>4 μF</td> <td>Short (0Ω)</td> </tr> </table>	Rated input	400VAC	Normal	Abnormal(faulty)	4 μF	Short (0Ω)	In the control panel of the rear side at compressor room																			
Rated input	400VAC																										
Normal	Abnormal(faulty)																										
4 μF	Short (0Ω)																										
Motor protector	 <p>Therminal check point</p> <table border="1" style="margin-bottom: 10px;"> <tr> <td>Model</td> <td colspan="2">5TM718MFBYY-53</td> </tr> <tr> <td rowspan="2">Connected Point</td> <td>Open</td> <td>120 ± 5° C</td> </tr> <tr> <td>Close</td> <td>69 ± 9° C</td> </tr> </table> <p>Measure the resistance with a tester.(Ambient temperature: Room temperature 15°C ~ 25°C)</p> <table border="1"> <tr> <td>Normal</td> <td>Abnormal(faulty)</td> </tr> <tr> <td>Less than 1Ω</td> <td>Opened (∞ Ω)</td> </tr> </table>	Model	5TM718MFBYY-53		Connected Point	Open	120 ± 5° C	Close	69 ± 9° C	Normal	Abnormal(faulty)	Less than 1Ω	Opened (∞ Ω)	Compressor in the machine chamber at the rear side of the frame													
Model	5TM718MFBYY-53																										
Connected Point	Open	120 ± 5° C																									
	Close	69 ± 9° C																									
Normal	Abnormal(faulty)																										
Less than 1Ω	Opened (∞ Ω)																										
PTC Relay	 <table border="1" style="margin-bottom: 10px;"> <tr> <td>Model</td> <td>PTH7M330MD2</td> </tr> </table> <p>Measure the resistance with a tester. (Ambient temperature: Room temperature 15°C ~ 25°C)</p> <table border="1"> <tr> <td>Normal</td> <td>Abnormal(faulty)</td> </tr> <tr> <td>33 Ω (Approx.)</td> <td>Opened (∞ Ω) or Short (0Ω)</td> </tr> </table> <p>As PTC Relay has been heated while refrigerator is running be sure to measure the resistance after the thermistor has got cool enough.</p>	Model	PTH7M330MD2	Normal	Abnormal(faulty)	33 Ω (Approx.)	Opened (∞ Ω) or Short (0Ω)	Compressor in the machine chamber at the rear side of the frame																			
Model	PTH7M330MD2																										
Normal	Abnormal(faulty)																										
33 Ω (Approx.)	Opened (∞ Ω) or Short (0Ω)																										

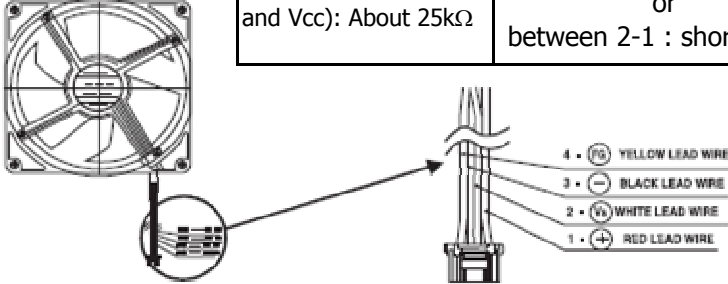
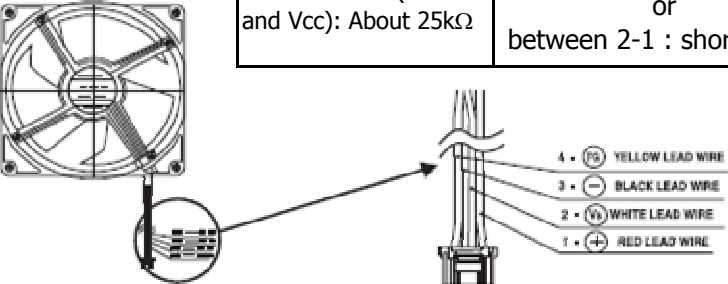
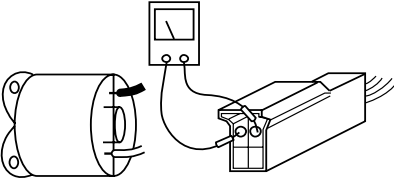
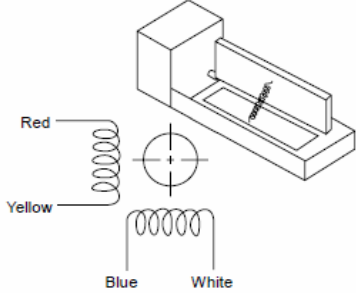
Components/ Part Name	Check Method and Criterion	Parts Mounted Position								
Refrigerator fan motor	<table border="1" data-bbox="711 322 1193 412"> <tr> <td>Model</td> <td>FBA12J12VXC</td> </tr> <tr> <td>Type</td> <td>DC brushless</td> </tr> </table> <p data-bbox="312 421 1184 452">Measure the resistance with a tester.(Ambient temperature:Room temperature 15°C ~ 25°C)</p> <table border="1" data-bbox="603 456 1193 618"> <tr> <th>Normal</th> <th>Abnormal (faulty)</th> </tr> <tr> <td>Between 3 - 1 (GND and Vcc): About 25kΩ</td> <td>Between 3-1 : open(∞ Ω) or between 2-1 : short (0 Ω)</td> </tr> </table> 	Model	FBA12J12VXC	Type	DC brushless	Normal	Abnormal (faulty)	Between 3 - 1 (GND and Vcc): About 25kΩ	Between 3-1 : open(∞ Ω) or between 2-1 : short (0 Ω)	In the fan grille of the refrigerator compartment.
Model	FBA12J12VXC									
Type	DC brushless									
Normal	Abnormal (faulty)									
Between 3 - 1 (GND and Vcc): About 25kΩ	Between 3-1 : open(∞ Ω) or between 2-1 : short (0 Ω)									
Machine chamber fan motor	<table border="1" data-bbox="711 882 1193 972"> <tr> <td>Model</td> <td>4715JL04WS16G51</td> </tr> <tr> <td>Type</td> <td>DC brushless</td> </tr> </table> <p data-bbox="312 981 1184 1012">Measure the resistance with a tester.(Ambient temperature:Room temperature 15°C ~ 25°C)</p> <table border="1" data-bbox="603 1016 1193 1178"> <tr> <th>Normal</th> <th>Abnormal (faulty)</th> </tr> <tr> <td>Between 3 - 1 (GND and Vcc): About 25kΩ</td> <td>Between 3-1 : open(∞ Ω) or between 2-1 : short (0 Ω)</td> </tr> </table> 	Model	4715JL04WS16G51	Type	DC brushless	Normal	Abnormal (faulty)	Between 3 - 1 (GND and Vcc): About 25kΩ	Between 3-1 : open(∞ Ω) or between 2-1 : short (0 Ω)	In the machine chamber at the rear side of the frame.
Model	4715JL04WS16G51									
Type	DC brushless									
Normal	Abnormal (faulty)									
Between 3 - 1 (GND and Vcc): About 25kΩ	Between 3-1 : open(∞ Ω) or between 2-1 : short (0 Ω)									
Water pump motor (DC 5V)	<p data-bbox="312 1438 1184 1469">Measure the resistance with a tester.(Ambient temperature:Room temperature 15°C ~ 25°C)</p>  <table border="1" data-bbox="711 1487 1155 1639"> <tr> <th>Normal</th> <th>Abnormal (faulty)</th> </tr> <tr> <td>16 Ω (Approx.)</td> <td>Open (∞Ω) or short circuit (0Ω)</td> </tr> </table>	Normal	Abnormal (faulty)	16 Ω (Approx.)	Open (∞Ω) or short circuit (0Ω)	Under the water tank holder in refrigerator compartment.				
Normal	Abnormal (faulty)									
16 Ω (Approx.)	Open (∞Ω) or short circuit (0Ω)									
Motor damper for refrigerator compartment/ slide compartment	<p data-bbox="312 1684 1184 1715">Measure the resistance with a tester.(Ambient temperature:Room temperature 15°C ~ 25°C)</p>  <table border="1" data-bbox="711 1738 1193 1939"> <tr> <th></th> <th>Normal</th> <th>Abnormal (faulty)</th> </tr> <tr> <td>Winding (Blue-White, Red-Yellow)</td> <td>415 Ω (Approx.)</td> <td>Open (∞ Ω) or short circuit (0Ω)</td> </tr> </table>		Normal	Abnormal (faulty)	Winding (Blue-White, Red-Yellow)	415 Ω (Approx.)	Open (∞ Ω) or short circuit (0Ω)	In the fan grille of the refrigerator compartment.		
	Normal	Abnormal (faulty)								
Winding (Blue-White, Red-Yellow)	415 Ω (Approx.)	Open (∞ Ω) or short circuit (0Ω)								

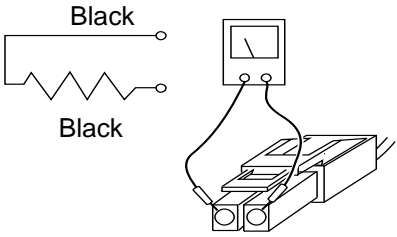
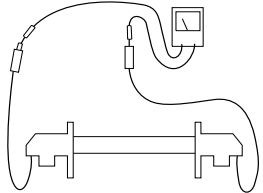
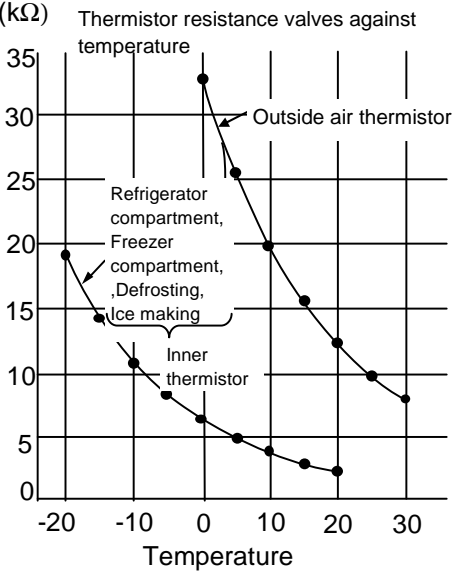
Components/ Part Name	Check Method and Criterion	Parts Mounted Position								
Water pipe heater	<p>Measure the resistance with a tester. (Ambient temperature: Room temperature 15°C ~ 25°C)</p>  <table border="1" data-bbox="774 392 1212 488"> <tr> <td>Normal</td> <td>Abnormal (faulty)</td> </tr> <tr> <td>1.3 kΩ (Approx.)</td> <td>Open (∞ Ω)</td> </tr> </table> <p>Operation method The heater is turned on when the temperature of tray for automatic ice making tray is about 10 °C or less</p>	Normal	Abnormal (faulty)	1.3 kΩ (Approx.)	Open (∞ Ω)	At the left bottom of vegetable compartment				
Normal	Abnormal (faulty)									
1.3 kΩ (Approx.)	Open (∞ Ω)									
Defrost Heater	 <table border="1" data-bbox="699 721 1177 833"> <tr> <td>Rated input</td> <td>155 W</td> </tr> <tr> <td>operation method</td> <td>Power ON after defrosting (14 ± 1.5°C or more)</td> </tr> </table> <p>Measure the resistance with a tester. (Ambient temperature: Room temperature 15°C ~ 25°C)</p> <table border="1" data-bbox="662 929 1212 1041"> <tr> <td>Normal</td> <td>Abnormal (faulty)</td> </tr> <tr> <td>372Ω (Approx.)</td> <td>Opened (∞ Ω)</td> </tr> </table>	Rated input	155 W	operation method	Power ON after defrosting (14 ± 1.5°C or more)	Normal	Abnormal (faulty)	372Ω (Approx.)	Opened (∞ Ω)	In the drip tray under the evaporator of the freezer compartment
Rated input	155 W									
operation method	Power ON after defrosting (14 ± 1.5°C or more)									
Normal	Abnormal (faulty)									
372Ω (Approx.)	Opened (∞ Ω)									
Thermistor	<p>Measure the resistance with a tester according to the following graph. (Thermistor resistance values against temperature)</p> <ul style="list-style-type: none"> Resistance measured under the ambient temperature from -50°C to +50 °C <ol style="list-style-type: none"> 200 Ω to 500kΩnormal Out of the above rangeabnormal <p>(kΩ) Thermistor resistance values against temperature</p>  <p>Thermistor Check Procedure</p> <ul style="list-style-type: none"> Thermistor resistance will vary with the change of temperature. Take the temperature around the thermistor, and then measure thermistor resistance using a tester. <p>The relation between resistance and temperature is as shown on the left side.</p> <p>Trouble shooting with self-check</p> <ol style="list-style-type: none"> If the self - check indicates the abnormality of thermistor right after the power is turned on, measure the resistance of the thermistor. <ul style="list-style-type: none"> If the circuit of thermistor is short , check the element of the thermistor and the contact of the connector. When the self - check indicates the abnormality of thermistor a few seconds after the power is turned on , check the contact of the connector. 	<p>(Defrost thermistor) Evaporator</p> <p>(Freezer compartment thermistor and Ice making tray thermistor) In Ice maker of freezer compartment</p> <p>(Refrigerator compartment thermistor) In the control panel of refrigerator compartment</p> <p>(Outside air thermistor) In the buzzer board (check board)</p>								

6.2 FUNCTION OF OPERATION PANEL

(1) Normal operation

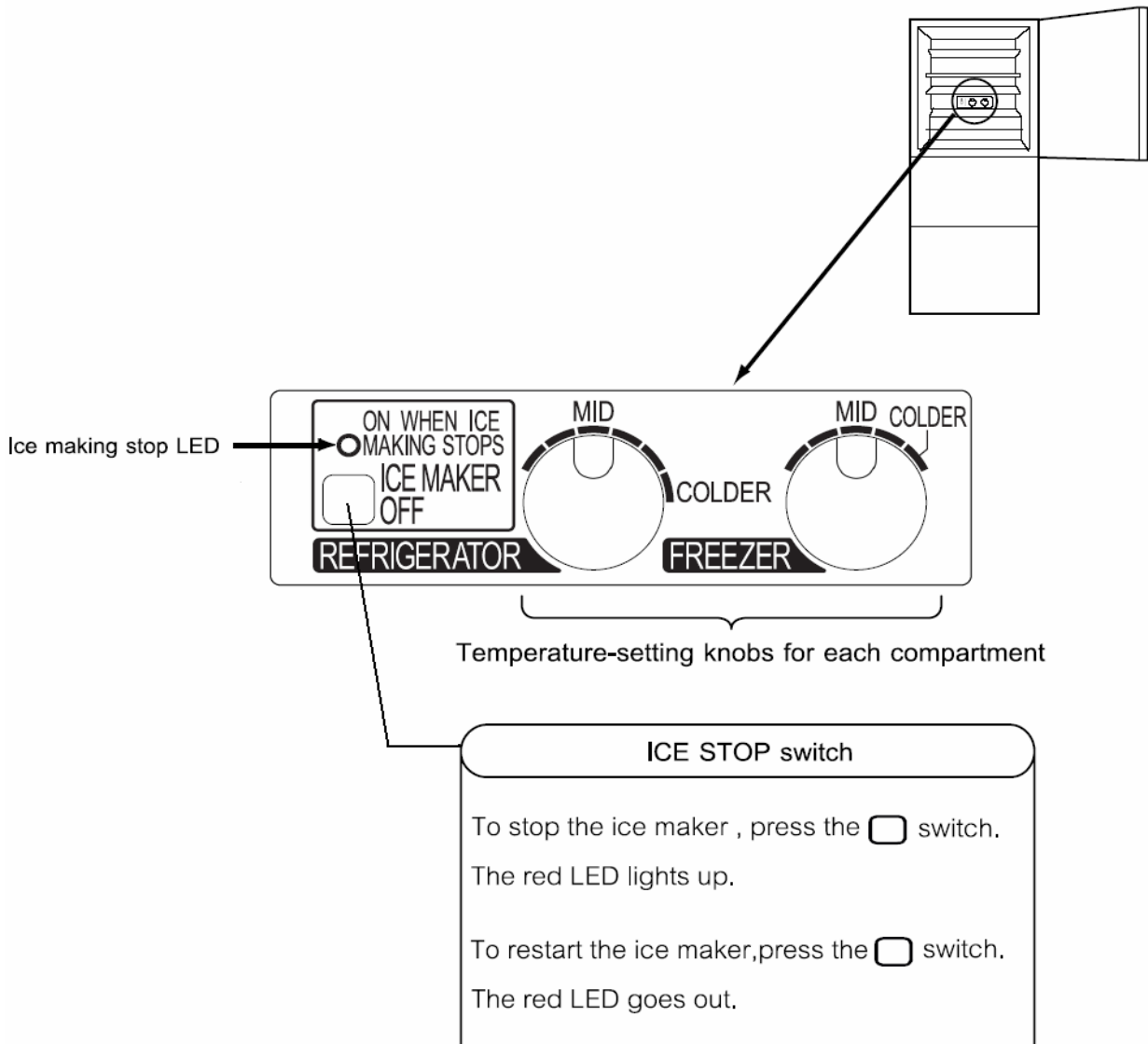

(2) Ice making test / Self-check

2.1 Setting

- Press the switch for 5 seconds

2.2 Operation and display

- During automatic ice making test,ice making stop LED blink.
- When something is faulty, the trouble is indicated with blinking number of ice making stop LED.(See page 13,14)
- Self-check finishes automatically. LED trouble display is also automatically released 10 minutes later. However,

the abnormal part has not been repair yet.

6.3 FLOW CHART OF SELF-CHECK

(1) Trouble shooting with self-check

This refrigerator has self-check feature to clarify and indicate where & what the trouble is. It can be checked that there is something wrong with electronic circuit and electric parts.

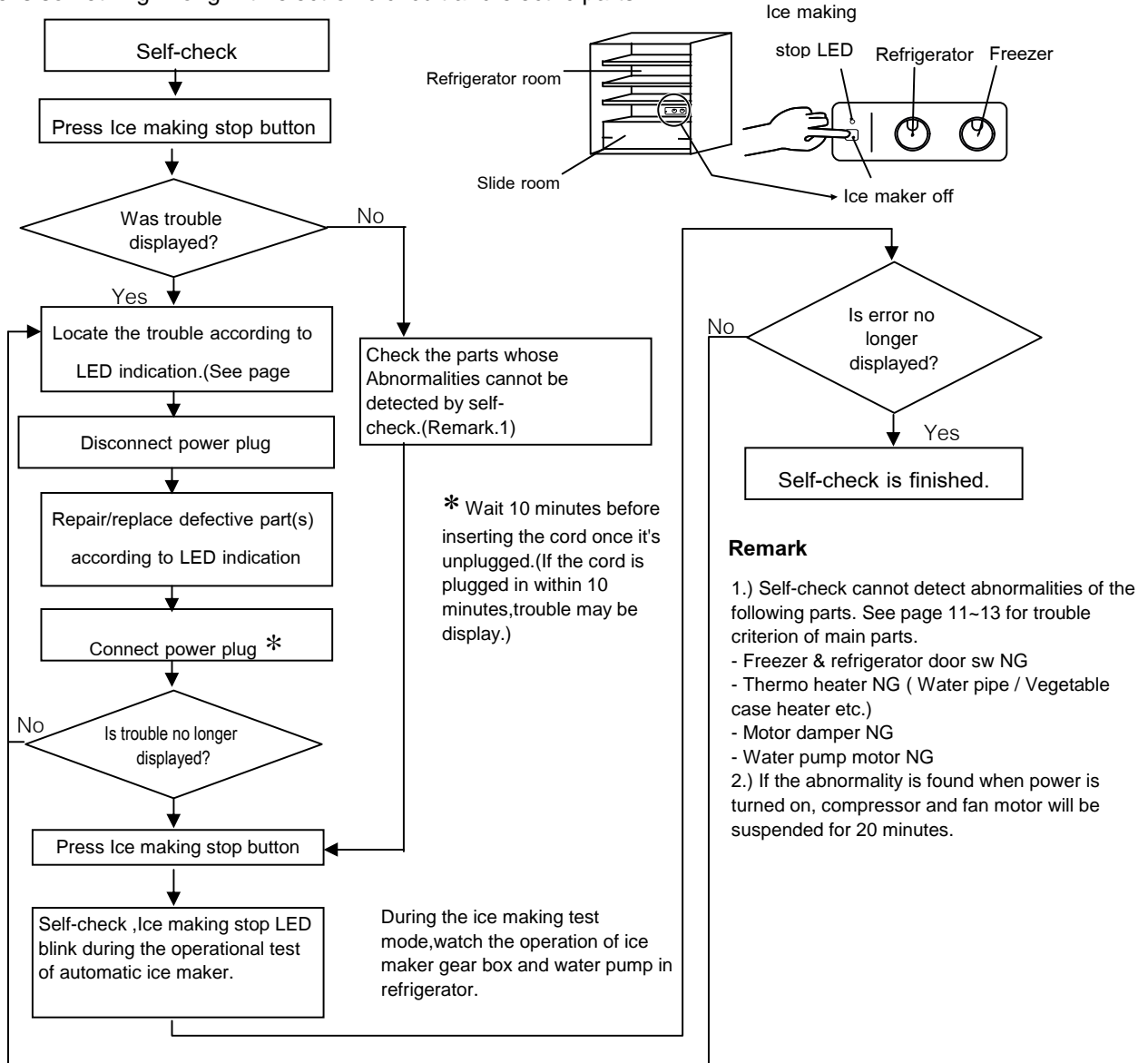

(2) Timing of self-check

- Defrost heater and related parts : Self-check is conducted after defrosting. (Make sure to confirm the display before unplugging because it is automatically reset once the power cord is pulled out.)
- Ice maker and related parts : To check the ice-making and then, check the blink amount of LED see the reference as (3)
- Fan motor and related parts : To check the blink amount of LED see the reference as (3)
- Thermistor and related parts : Self-check is continuously working.

Caution: The self-check will automatic start to begin power supply. But in the portion of the abnormality show the detail as (3) .

And the caution checking couldn't be summarized, please use self-check means by using operation panel.

(3) LED trouble display and the check point

(3.1) LED trouble display : follow the procedure of "self check method and its operation" at page 11. Trouble is indicated by the blinking number of ice making stop LED.

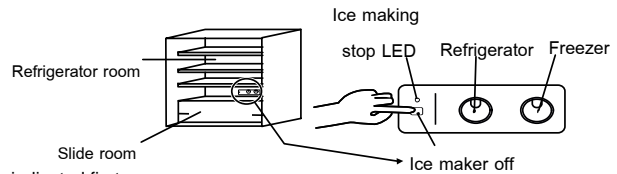

* When several troubles occur, smaller blinking number of LEDs has to be indicated first.

(3.2) Check point and treatment

Function	Explanation	Detecting method and corrective NG points	Display function of LED
Off	<p>Normal</p> <p>1. Normally display and the Auto ice-maker system display.</p> <p>* If non-power supply, it'll show as same the effect.</p>	NO	<p>Light</p> <p>No Light _____</p>
Blink 0.1 second	<p>Auto ice maker NG</p> <p>1. The connector lead wire of Auto ice maker is not orderly.</p> <p>2. Auto ice maker (Motor's not rotate and non-display)</p> <p>3. PCB plate (Ref Con assy) NG</p>	<p>1. Check all points of the Auto ice maker connector lead wire. May be un-lock and struck insert.</p> <p>2. Replace and re-check the Auto ice maker.</p> <p>3. Replace and re-check the PCB plate (Ref Con assy)</p>	
Blink 0.3 seconds	<p>Thermistor(I) NG</p> <p>1. The connector thermistor (I) lead wire isn't orderly.</p> <p>2. Thermistor (I) NG (break or short)</p> <p>3. PCB plate (Ref Con assay) NG</p>	<p>1. Check all points of the thermistor (I) connector lead wire, may be unlock and struck insert.</p> <p>2. If the resistance of thermistor (I) is NG, should be changed the thermistor and re-check the resistance.</p> <p>3. If the resistance is OK,should be changed PCB plate (Ref Con assy and re-check the resistance).</p>	
1 Blink	<p>Thermistor (F) NG</p> <p>1. The connector thermistor (F) lead wire isn't orderly.</p> <p>2. Thermistor (F) NG (break or short)</p> <p>3. PCB plate (Ref Con assy) NG</p>	<p>1. Check all points of the thermistor (F) connector lead wire, may be unlock and struck insert.</p> <p>2. If the resistance of thermistor (F) is NG,should be changed the thermistor and re-check the resistance.</p> <p>3. If the resistance is OK,should be changed PCB plate (Ref Con assy and re-check the resistance).</p>	
2 Blinks	<p>Thermistor (DEF) NG</p> <p>1. The connector DEF. thermistor lead wire isn't orderly.</p> <p>2. Thermistor (DEF) NG (break or short)</p> <p>3. PCB plate (Ref Con assy) NG</p>	<p>1. Check all points of the thermistor (DEF) connector lead wires, may be unlock and struck insert.</p> <p>2. If the resistance of thermistor (DEF) is NG,should be changed the thermistor and re-check the resistance.</p> <p>3. If the resistance is OK,should be changed PCB plate (Ref Con assy and re-check the resistance).</p>	
3 Blinks	<p>Defrost heater NG</p> <p>1. The Defrost heater connector lead wire isn't orderly.</p> <p>2. Defrost heater break or Thermal fuse break.</p> <p>3. PCB plate (Ref Con assy) break.</p>	<p>1. Check all points of the defrost heater connector lead wire, may be un-lock and struck insert.</p> <p>2. Check the resistance of the defrost heater and thermal fuse.</p> <p>3. If the resistance is OK,should be changed PCB plate (Ref Con assy and re-check the resistance).</p>	

Function	Explanation	Detecting method and corrective NG points	Display function of LED
4 Blinks	<p><u>Thermistor (R) NG</u></p> <ol style="list-style-type: none"> The Thermistor (R) connector lead wire isn't orderly. Thermistor (R) NG (break or short) PCB plate (Ref Con assy) NG 	<ol style="list-style-type: none"> Check all points of Thermistor (R) connector lead wire, may be unlock and struck insert. If the resistance of Thermistor (R) is NG, should be replaced the Thermistor (R) and re-check the resistance. If the resistance is OK., should be replaced PCB plate (Ref Con assy) and re-check the resistance. 	<p>1 Cycle</p> <p>Light</p> <p>No Light</p> <p>0.3 sec</p> <p>5 sec</p>
6 Blinks	<p><u>Thermistor (A.T.) NG</u></p> <ol style="list-style-type: none"> The Thermistor (A.T.) connector lead wire isn't orderly. Thermistor (A.T.) NG (break or short) PCB plate (Ref Con assy) NG 	<ol style="list-style-type: none"> Check all points of the thermistor (A.T.) connector lead wire, may be unlock and struck insert. If the resistance of Thermistor (A.T) is NG, should be replaced the Thermistor (R) and re-check the resistance. If the resistance is OK., should be replaced PCB plate (Ref Con assy) and re-check the resistance. 	<p>1 Cycle</p> <p>Light</p> <p>No Light</p> <p>0.3 sec</p>
10 Blinks	<p><u>Fan motor (Fan grille assy) NG</u></p> <ol style="list-style-type: none"> DC motor is orderly connected. DC motor NG (Motor un-rotate and non-display) PCB plate (Ref Con assy) NG 	<ol style="list-style-type: none"> Check all points of DC motor connector lead wire, may be unlock and struck insert. Replace DC motor (Fan grille assy) and re-check display. If the resistance is OK., should be replaced PCB plate (Ref Con assy) and re-check the resistance. 	<p>1 Cycle</p> <p>Light</p> <p>No Light</p> <p>0.3 sec</p>
11 Blinks	<p><u>Fan motor (Outer motor assy) NG</u></p> <ol style="list-style-type: none"> DC fan motor is orderly connected. DC fan motor NG (Motor un-rotated, and non-display.) PCB plate (Ref Con assy) NG 	<ol style="list-style-type: none"> Check all points of DC Fan motor connector lead wire, may be unlock and struck insert. Replace DC fan motor (Outer motor assy) and check display. If the resistance is OK., should be replaced PCB plate (Ref Con assy) and re-check the resistance. 	<p>1 Cycle</p> <p>Light</p> <p>No Light</p> <p>0.3 sec</p>
16 Blinks	<p><u>PCB plate (Ref Con assy) NG</u></p> <ol style="list-style-type: none"> PCB program (Ref Con assy) is NG 	<ol style="list-style-type: none"> Replace a new PCB plate (Ref Con assy) 	<p>1 Cycle</p> <p>Light</p> <p>No Light</p> <p>0.3 sec</p>
19 Blinks	<p><u>Refrigerant circuit is NG.</u></p> <ol style="list-style-type: none"> Pipe cracked (Welding joint) Gas leak Compressor NG 	<ol style="list-style-type: none"> Check and corrective to each problem. 	<p>1 Cycle</p> <p>Light</p> <p>No Light</p> <p>0.3 sec</p>

Remark :

- For the refrigerator is NG more than one case, will show as the first symptoms before, such as Thermistor (F) NG (1 blink in 0.3 seconds) and Thermistor (R) NG (4 blinks in 0.3 seconds). LED will blink 1 blink in 0.3 seconds until Thermistor (F) was corrected. Then change to 4 blinks in 0.3 seconds and LED won't blink when Thermistor (R) was corrected.
- Ice making stop LED blink during the operational test for ice maker.
- Compressor won't work if the fridge have problem and LED blink
- Characteristic value may be changed due to the product improvement

6.4 TEST POINT DIAGRAM OF MAIN CONTROL BOARD

MR-C375C-A

MR-C375CL-A

MR-C405C-A

MR-C405CL-A

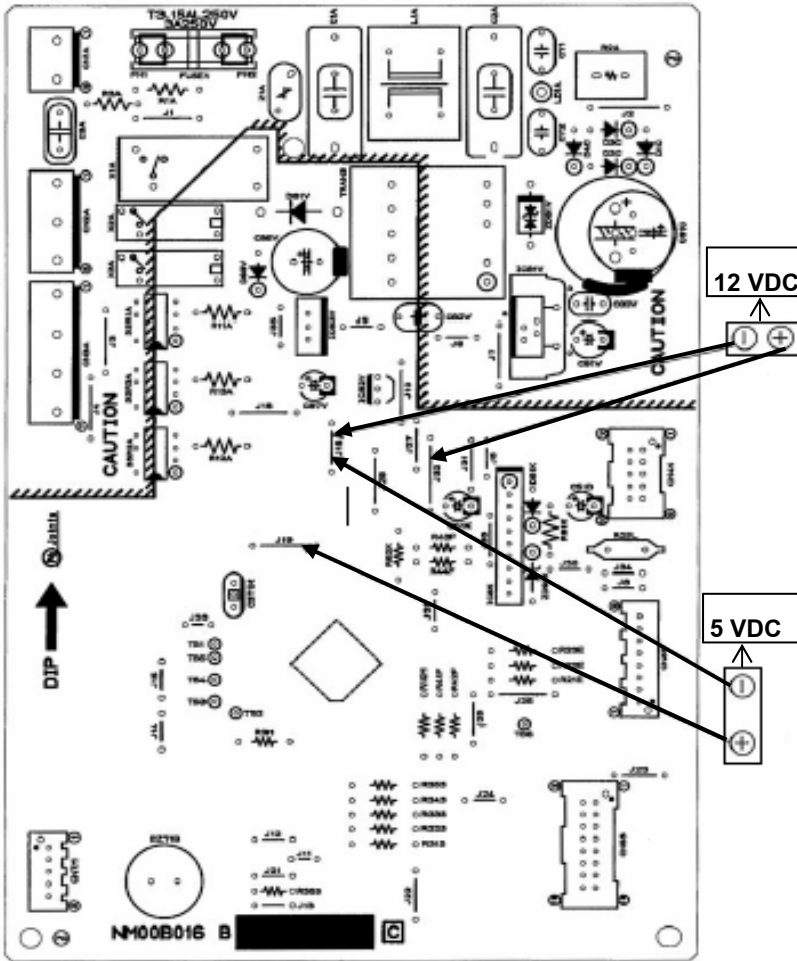

CN4K	Lead color	Parts Name
1		
2	Red	Damper
3	Gray	Ice Maker Positon SW
4	Bright Yellow	Damper
5	Pink	Ice Maker & Water Pump Forward
6	White	Damper
7	Brown	Ice Maker Reverse
8	Blue	Damper
9		
10	Yellow/Green	Water Pump

CN5F	Lead color	Parts Name
8	Violet	12 VDC Common
7	Violet	12 VDC Common
6	Black	GND
5	Pink	GND
4	Orange	Outer Fan Motor FG
3	Bright Yellow	Inner Fan Motor FG
2	Light Green	Outer Fan Motor Vs
1	White	Inner Fan Motor Vs

CN6S	Lead color	Parts Name
1		
2		
3		
4	Yellow	Ice Maker Stop SW
5	Red	Ice Maker Stop LED
6		
7		
8	Blue	F Thermistor
9	Bright Yellow	Temp Control Board
10	Orange	R Thermistor
11	Gray	Temp Control Board
12	Light Green	I Thermistor
13	Sky Blue	5 VDC Common
14	Pink	DEF Thermistor
15	Black	GND
16	Brown	Door SW

CN1A	Lead color	Parts Name
1	Grey	220 VAC
3	Black	

CN2A	Lead color	Parts Name
1	Grey	220 VAC Common
3	White	Compressor
5	Red	Defrost Heater

CN3A	Lead color	Parts Name
1	Yellow	Lamp
3	Yellow/Green	V Heater
5	Brown	Ice Maker Heater
7	Sky Blue	Pipe Heater

CN7M	Lead color	Parts Name
1	White	12 VDC Common
2	Red	Buzzer
3	Violet	A.T. Thermistor
4	Sky Blue	5 VDC Common
5	Grey	Compulsion DEF

Compulsory defrosting method have 2 methods as below

- 1) Short circuit at 2-pin connector between no.6 (white wire) with no.7 (red wire) at Buzzer & Thermistor A.T. board.(Inside hinge cover)
- 2) Open door R and then adjust dial freezer at MID position. Use magnet touch door switch in order to simulate as door closing. (lamp must no light),then turn the dial continuously as follow COLDER → LOW → MID

MR-C375C-A

MR-C375CL-A

MR-C405C-A

MR-C405CL-A

Plug out before work.

Check the automatic ice-maker by pressing ice making stop switch.

In assembling & disassembling parts use several kind of screws and rivets. Do not mistake to use them.

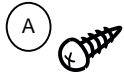

4 x12 Stainless steel



4 x12 (Black) With metal washer



Rivet

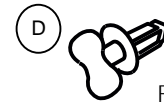

Rivet

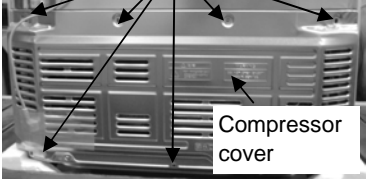
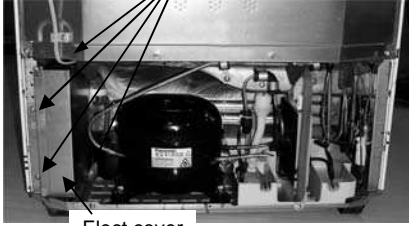
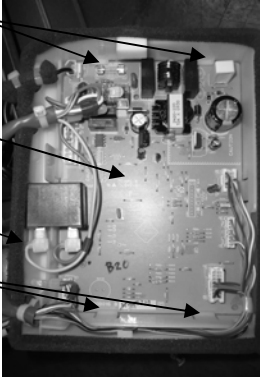
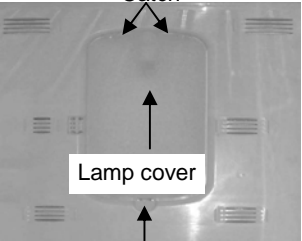
OPERATING PROCEDURE	PHOTOS
<p>1. Detachment Control PCB parts</p> <p>Compressor cover</p> <p>(1) Detach 7 pcs. of compressor cover screws behind the refrigerator. (Photo 1)</p> <p>Elect cover</p> <p>(2) Detach 4 pcs. of Elect cover screws. (Photo 2)</p> <p>Elect attach</p> <p>(3) Disconnect the connector and remove Elect attach. (Photo 3)</p> <p>PCB (Refcon assy)</p> <p>(4) Remove the catch of elect attach to release the PCB plate. (Photo 3)</p> <p>Caution on assembly</p> <p>[1] Firmly connect the lead wire and the connector. Ensure the wire are not pinched.</p> <p>[2] Please use the new material of sealing insulation when re-attach.</p>	<p>Photo 1</p> <p>7 fixing screws</p>  <p>Compressor cover</p> <p>Photo 2</p> <p>4 fixing screws</p>  <p>Elect cover</p> <p>Photo 3</p> <p>Catch</p> <p>PCB</p> <p>Elect attach</p> <p>Catch</p> 
<p>2. Detachment Lamp cover parts</p> <p>(1) Remove parts inside the refrigerator Shelf 1,2,3 shelf</p> <p>Lamp cover inside the refrigerator</p> <p>(1) Push up the lower catch, and pull the room light cover toward you.</p> <p>(2) Detach two upper catches to take out the cover (Photo 4)</p>	<p>Photo 4</p> <p>Catch</p>  <p>Lamp cover</p> <p>Catch</p>

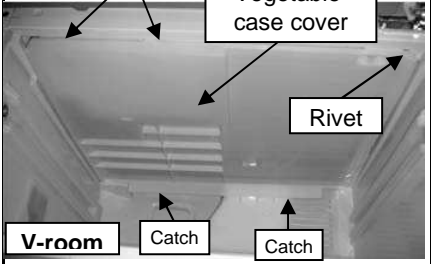
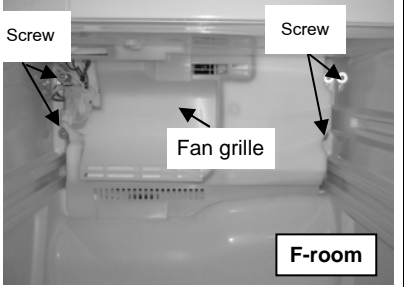
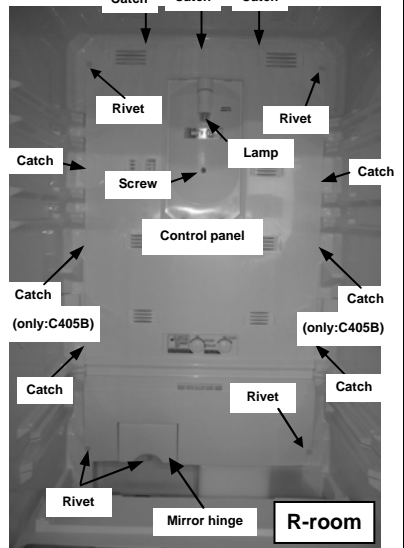

OPERATING PROCEDURE	PHOTOS
<p>3. Detachment the Vegetable case parts</p> <p>(1) Detach parts inside vegetable compartment (Vegetable case, Fruit case).</p> <p>(2) Detach the door of vegetable compartment.</p> <p>(3) Detach rivet (C) at the right and unhooking 2 catches at front, (center and left). (Photo 5)</p> <p>Caution on assembly</p> <p>[1] Be sure to put vegetable case cover on the catches at the rear of vegetable compartment.</p> <p>Water pump motor</p> <p>(4) Remove two screws and cut the lead wire of water-pump motor to detach it.</p>	<p>Photo 5</p>  <p>V-room</p>
<p>4. Detach the refrigerator room parts</p> <p>(1) Detach parts inside the refrigerator compartment.</p> <p>(2) Detach parts inside the vegetable compartment.</p> <p>(3) Detach a left screw of mirror hinge and pull out the lead wire. (Photo 7)</p> <p>(4) Detach the connector.</p> <p>Control panel , Duct R, Temperature control panel</p> <p>(5) Remove the upper and lower rivets (C) of right side and left side, then unhook 7 catches.(9 catches for C405B)</p> <p>* Remove the right catch before push the control panel to the right and detach it. (Photo 7)</p> <p>Fan grille</p> <p>(6) Remove the following; Screw (A) at the upper and right center, 2 screws (B) at the left and 2 screws (B) at the right. (Photo 6)</p> <p>* Motor damper and thermal fuse are combined with fan grille.</p> <p>* Fan and fan motor are combined with fan grille.</p> <p>Caution on assembly</p> <p>[1] Use new tapes and sealing materials for assembly.</p> <p>[2] Putting some tape across joints, tape them securely so that they will not leak the cool air.</p> <p>[3] Attach a connector securely in order to prevent contact failure.</p>	<p>Photo 6</p>  <p>F-room</p> <p>Photo 7</p>  <p>R-room</p>

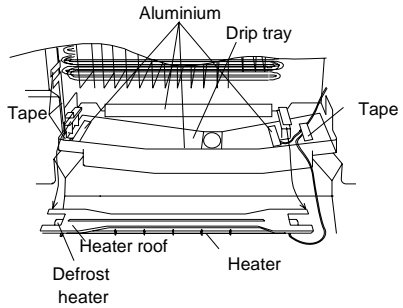
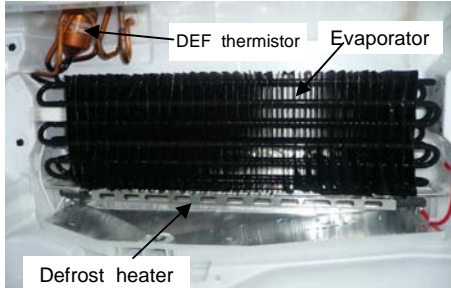
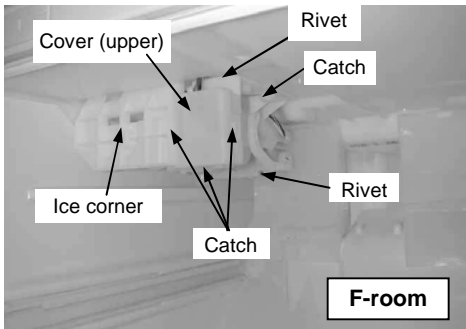

OPERATING PROCEDURE	PHOTOS
<p>Defrost heater, Drip tray</p> <p>(7) Peel off the tape that fixes lead wires on the side wall of the vegetable compartment. Then take out defrost heater together with heater roof.</p> <p>Detach heater roof and Heater cover from Defrost heater.</p> <p>Detach the drip tray after removing the defrost heater.</p> <p>Defrost thermistor</p> <p>(8) Cut the binder and disconnect the connector. (Photo 9)</p> <p>Caution on assembly</p> <p>[1] Loosen the lead wire at the defrost heater to prevent water from entering the glass tube and careful the direction for the correct assembly.</p> <p>[2] Attach the drip tray securely to the lower parts.</p> <p>[3] Attach the defrost thermistor in the correct place. (If they're attached out of place, thermal characteristics will go wrong).</p> <p>[4] Attach the lead wires to the fixture.</p>	<p>Photo 8</p>  <p>Aluminium Drip tray Tape Tape Heater roof Defrost heater Heater</p> <p>Photo 9</p>  <p>DEF thermistor Evaporator Defrost heater</p>
<p>5 Detachment the parts in Freezer compartment</p> <p>(1) Detach the parts inside the Freezer room (Ice spoon, Freezing case [upper] and Freezing case [lower]).</p> <p>(2) Pull the door of Freezer compartment by pulling toward you.</p> <p>Cover (upper)</p> <p>(3) Detach 3 catches and remove it. (Photo 10)</p> <p>(4) Disconnect the connector.</p> <p>Automatic ice-maker</p> <p>(5) push a catch to upper and pull the part to the right and detach it. (Photo 10)</p>	<p>Photo 10</p>  <p>Cover (upper) Rivet Catch Ice corner Catch Rivet F-room</p>

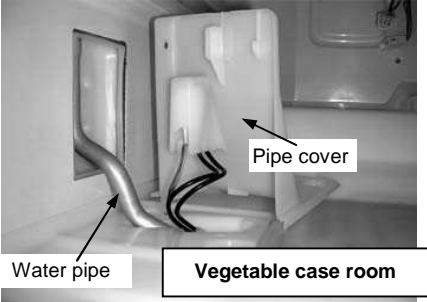
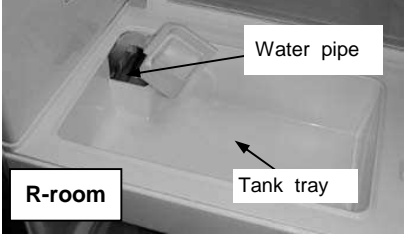

OPERATING PROCEDURE	PHOTOS
<p>6 Detachment the vegetable compartment parts</p> <p>(1) Detach the door of the vegetable compartment.</p> <p>Water pipe (lower)</p> <p>(2) Detach a rivet (C), pipe cover and connector. Then remove the water pipe lower.</p> <p>Water tank tray</p> <p>(3) Pull Tank tray to R-room upper and take it out together with the water pipe.</p> <p>Caution on assembly</p> <p>(1) Fit the water tank tray properly in order to prevent a water leak.</p> <p>Door Switch</p> <p>(4) Insert a minus screwdriver between switch and body to remove the door switch.</p>	<p>Photo 11</p>  <p>Photo 12</p> 

OPERATING PROCEDURE

Compressor cover

- (1) Remove 7 screws for compressor cover at the back of the refrigerator.

Fan motor of compressor compartment

- (2) Detach the Elect cover
- (3) Detach the Connector.
- (4) Remove a screw that fixed bell mouth. Pull out the whole fan motor and disconnect the terminals.
- (5) Pull out the fan from the fan motor.
- (6) Detach the lid-fixing screw to take out the fan motor.

7 Detachment compressor.

- (1) Collect gas from the charge pipe on the high pressure side.
- (2) After collecting gas, cut the charge pipe on the low pressure side.
- (3) Detach the welded section of the discharge pipe and suction pipe.
- (4) Replace the compressor and the dryer at a time.

Caution on assembly

- (1) After attaching the compressor, must to Vacuum and charge gas from charge pipe.
- (2) Arrange the piping so that the pipe will not hit each other and compressor cover, (which causes loud noise). Then attach the compressor cover.
- (3) After all the work is complete, be sure to check the cooling performance and the gas leak from the welded points.

Attach U washer as the figure shown below

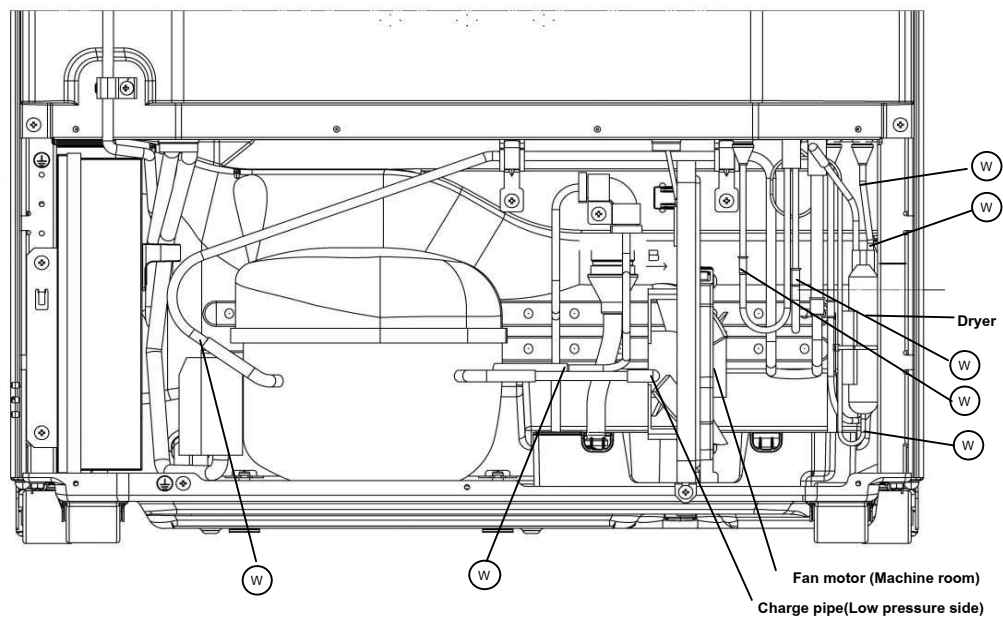
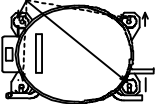

(W) : This mark shown welded point

DOOR, BODY PARTS

MR-C375C-A

MR-C375CL-A

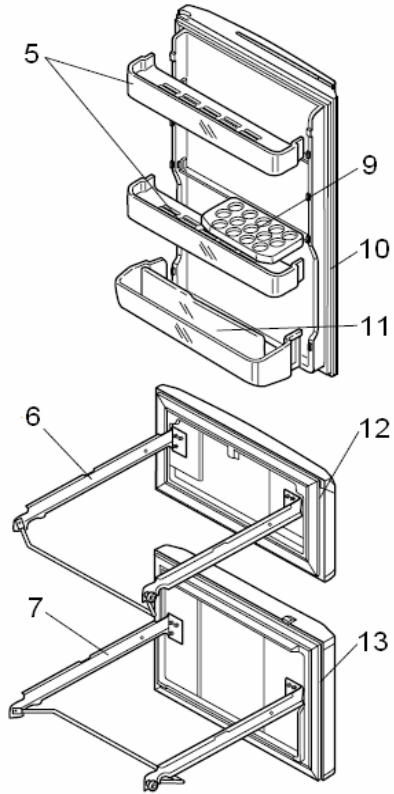
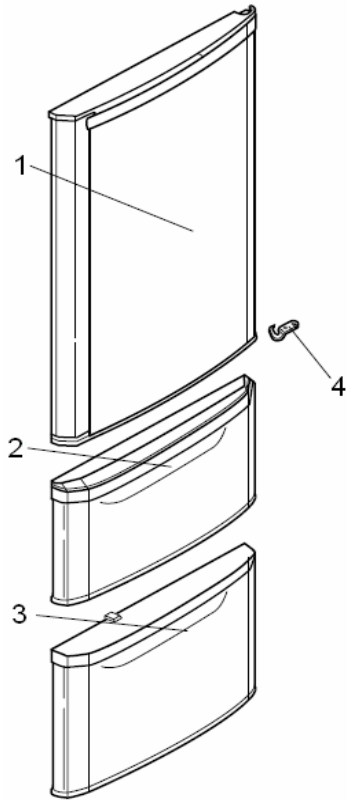

MR-C405C-A

MR-C405CL-A

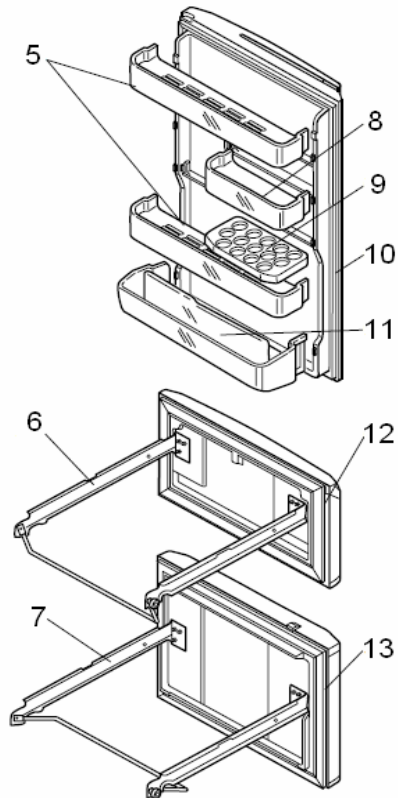
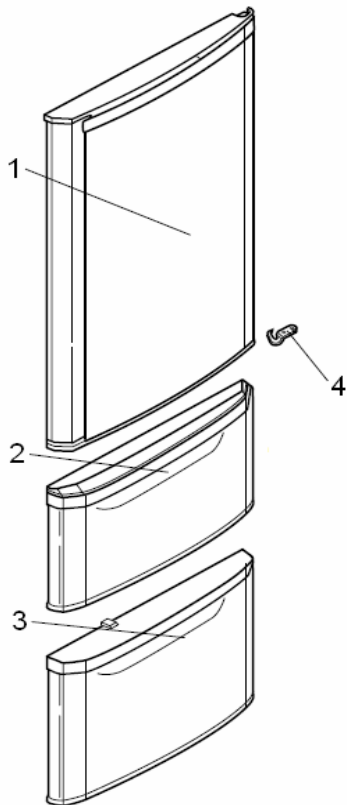

NO.	PART NO.	RoHS	PART NAME	SPEC	QTY/UNIT								PRICE/PIE CE(US\$- FOB)
					MR-C375C-A		MR-C375CL-A		MR-C405C-A		MR-C405CL-A		
					W	ST	W	ST	W	ST	W	ST	
1	KIERL6000	<G>	DOOR R		1								
	KIER66000	<G>				1							
	KIERN6000	<G>					1						
	KIERN7000	<G>						1					
	KIERL8000	<G>							1				
	KIER71000	<G>								1			
	KIERP0000	<G>									1		
	KIERP1000	<G>										1	
2	KIEPE2002	<G>	DOOR V		1		1		1		1		
	KIEP91002	<G>				1		1		1		1	
3	KIEPE2001	<G>	DOOR F		1		1		1		1		
	KIEP91001	<G>				1		1		1		1	
4	KIEG05741	<G>	CATCHER RH		1	1			1	1			
	KIEPE4741	<G>	CATCHER LH				1	1			1	1	
5	KIEP89118	<G>	FREE POCKET L		2	2	2	2	2	2	2	2	
6	KIEP89151	<G>	FRAME V ASSY		1	1	1	1	1	1	1	1	
7	KIEP89157	<G>	FRAME F ASSY		1	1	1	1	1	1	1	1	
8	KIEP89119	<G>	FREE POCKET S						1	1	1	1	
9	KIEHJ3115	<G>	EGG CASE		1	1	1	1	1	1	1	1	
10	KIEP89112	<G>	MAGNET GASKET ASSY (R)		1	1	1	1					
	KIEP89111	<G>							1	1	1	1	
11	KIEP89124	<G>	BOTTLE POCKET		1	1	1	1	1	1	1	1	
12	KIEP89112	<G>	MAGNET GASKET ASSY (V)		1	1	1	1	1	1	1	1	
13	KIEP89111	<G>	MAGNET GASKET ASSY (F)		1	1	1	1	1	1	1	1	
⑭	KIERN0031	<G>	BADGE ASSY		1		1		1		1		
	KIER72031	<G>				1		1		1		1	

RECOMMEND PART NO. 1, 2, 3, 10, 12, 13

ABBREVIATION

F	FREEZER ROOM	V	VEGETABLE ROOM
R	REFRIGERATOR ROOM		

ENCIRCLED PART NUMBER ARE NOT SHOWN IN THE FIGURES.

Remark

- Country code : A= Australia and New Zealand
- Colour code : W = White, ST = Stainless

BODY PARTS

MR-C375C-A
MR-C375CL-A
MR-C405C-A
MR-C405CL-A

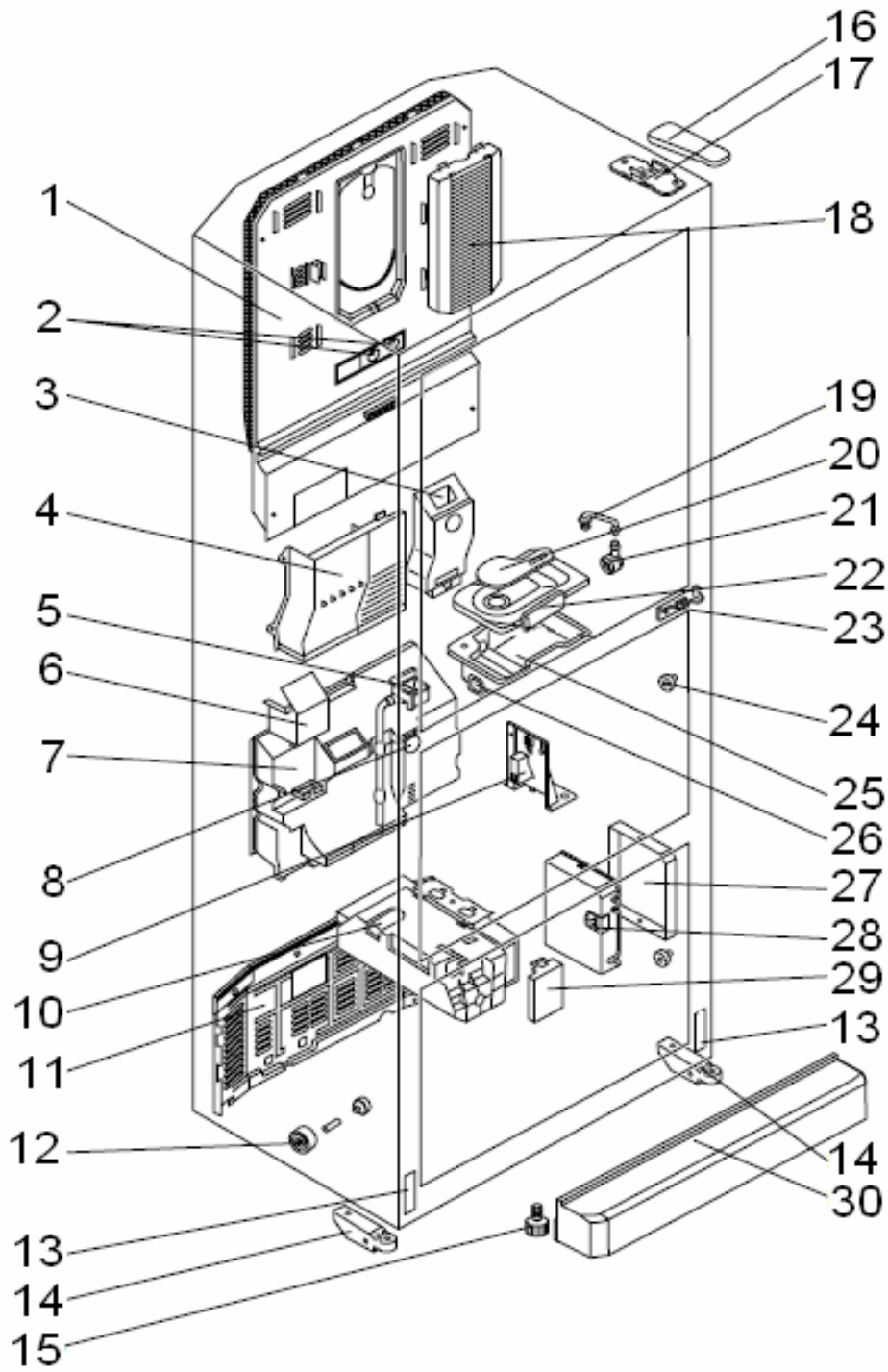

NO.	PART NO.	RoHS	PART NAME	SPEC	Q'TY/UNIT								PRICE/PIECE(USS-FOB)
					MR-C375C-A		MR-C375CL-A		MR-C405C-A		MR-C405CL-A		
					W	ST	W	ST	W	ST	W	ST	
1	KIEP89858	<G>	CONTROL PANEL		1	1	1	1					
	KIEP94858	<G>						1	1	1	1		
2	KIEHJ3305	<G>	THERMO DIAL (R)		2	2	2	2	2	2	2	2	
3	KIEP89802	<G>	DUCT V ASSY		1	1	1	1	1	1	1	1	
4	KIEP89818	<G>	COVER DUCT V		1	1	1	1	1	1	1	1	
5	KIEP89503	<G>	WATER TRAY ASSY		1	1	1	1	1	1	1	1	
6	KIEP89808	<G>	CONNECTOR COVER		1	1	1	1	1	1	1	1	
7	KIEPE2663	<G>	FAN GRILLE ASSY		1	1	1	1	1	1	1	1	
8	KIEHJ3708	<G>	LABEL FC		1		1		1		1		
	KIEP91708	<G>				1		1		1		1	
9	KIEP89442	<G>	PIPE COVER		1	1	1	1	1	1	1	1	
10	KIEPE2350	<G>	AUTO ICE MAKER		1	1	1	1	1	1	1	1	
11	KIEP89652	<G>	COMP COVER ASSY		1	1	1	1	1	1	1	1	
12	KIE805794	<G>	CASTER SET		2	2	2	2	2	2	2	2	
13	KIEHJ3709	<G>	SCREW LABEL (F)		2	2	2	2	2	2	2	2	
14	KIEH79795	<G>	CASTER ASSY		2	2	2	2	2	2	2	2	
15	KIEC02460	<G>	ADJUST BOLT		2	2	2	2	2	2	2	2	
16	KIER65705	<G>	HINGE COVER		1				1				
	KIEP91705	<G>				1				1			
	KIERN6705	<G>					1				1		
	KIEPE5705	<G>						1				1	
17	KIEP89701	<G>	HINGE ASSY (UP)		1	1			1	1			
	KIEPE4701	<G>					1	1			1	1	
18	KIEP89470	<G>	LAMP COVER		1	1	1	1	1	1	1	1	
19	KIEHJ4503	<G>	JOINT PIPE (TANK)		1	1	1	1	1	1	1	1	
20	KIEHJ3531	<G>	WATER TANK CAP		1	1	1	1	1	1	1	1	
21	KIEHJ3519	<G>	WATER PUMP		1	1	1	1	1	1	1	1	
22	KIEK96527	<G>	WATER TANK COVER ASSY		1	1	1	1	1	1	1	1	
23	KIEMT0702	<G>	HINGE ASSY (LOW)		1	1			1	1			
	KIEHJ2702	<G>					1	1			1	1	
24	KIEHJ3798	<G>	ROLLER		4	4	4	4	4	4	4	4	
25	KIEHJ3520	<G>	WATER TANK		1	1	1	1	1	1	1	1	
26	KIEHJ3526	<G>	FILTER (TANK)		1	1	1	1	1	1	1	1	
27	KIEP89328	<G>	ELECT BOX COVER ASSY		1	1	1	1	1	1	1	1	
28	KIEMQ4326	<G>	ELECT BOX SUB ASSY		1	1	1	1	1	1	1	1	
29	KIEHJ4442	<G>	COVER (IM)		1	1	1	1	1	1	1	1	
30	KIEPE2730	<G>	KICK PLATE		1		1		1		1		
	KIEP91730	<G>				1		1		1		1	
31	KIEPJ5663	<G>	FAN GRILLE		1	1	1	1	1	1	1	1	
32	KIEP94662	<G>	BELL MOUTH		1	1	1	1	1	1	1	1	
33	KIEHJ4682	<G>	DUCT DAMPER		1	1	1	1	1	1	1	1	
34	KIEP89336	<G>	THERMAL FUSE ASSY		1	1	1	1	1	1	1	1	

RECOMMEND PART NO. 7, 20, 22, 34

ABBREVIATION

F	FREEZER ROOM	IM	ICE MAKER
R	REFRIGERATOR ROOM	V	VEGETABLE ROOM

ENCIRCLED PART NUMBER ARE NOT SHOWN IN THE FIGURES.

ELECTRICIAL PARTS

MR-C375C-A

MR-C375CL-A

MR-C405C-A

MR-C405CL-A

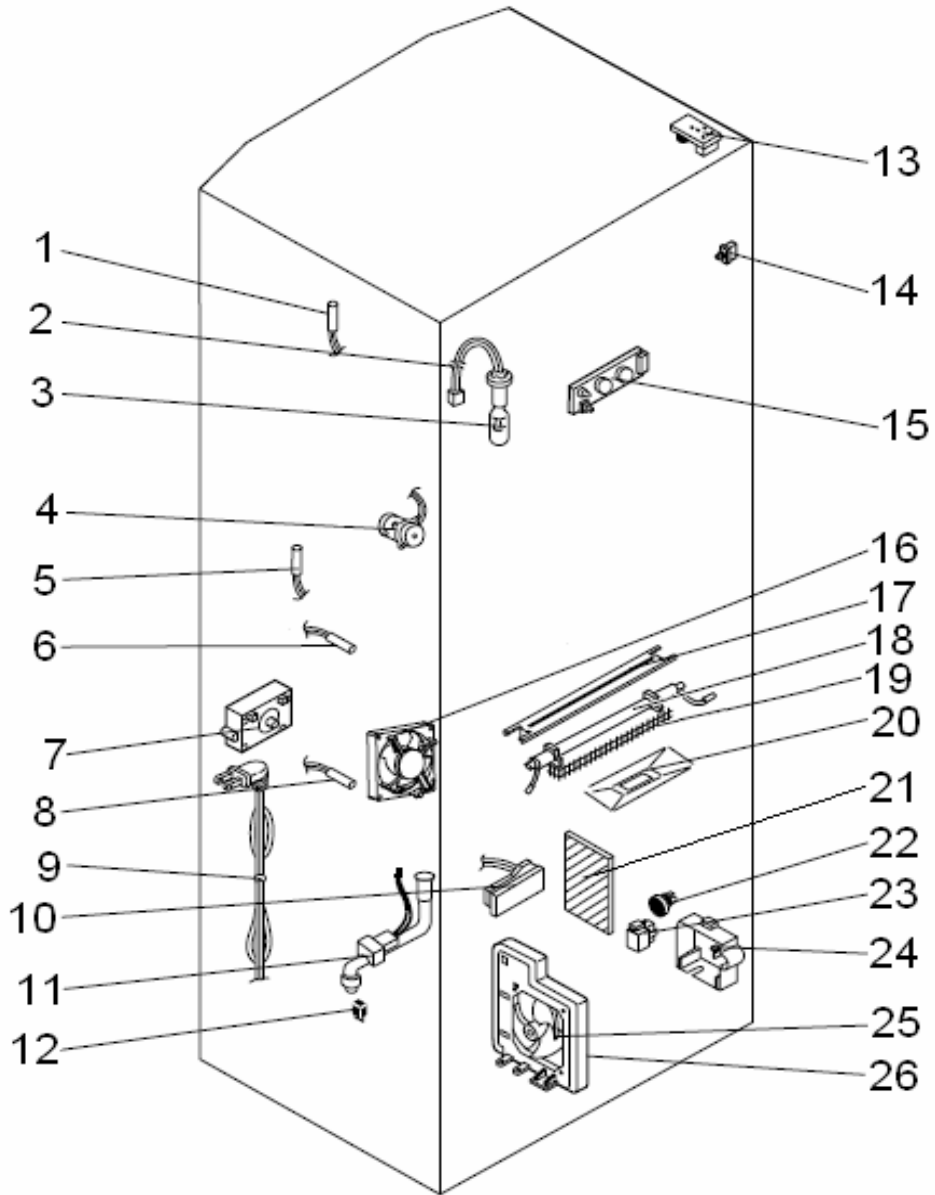

NO.	PART NO.	RoHS	PART NAME	SPEC	Q'TY/UNIT								PRICE/PIECE (US\$-FOB)
					MR-C375C-A		MR-C375CL-A		MR-C405C-A		MR-C405CL-A		
					W	ST	W	ST	W	ST	W	ST	
1	KIEHJ3313	<G>	THERMISTOR (R)		1	1	1	1	1	1	1	1	
2	KIEP89386	<G>	LAMP SOCKET		1	1	1	1					
	KIEP94386	<G>						1	1	1	1		
3	KIE402360	<G>	LAMP	240V 15W E12	1	1	1	1	1	1	1	1	
4	KIEHJ3365	<G>	WATER PUMP		1	1	1	1	1	1	1	1	
5	KIEP89312	<G>	THERMISTOR (DEF)		1	1	1	1	1	1	1	1	
6	KIEHJ3378	<G>	THERMISTOR (F)		1	1	1	1	1	1	1	1	
7	KIEHJ3469	<G>	GEAR BOX (IM)		1	1	1	1	1	1	1	1	
8	KIEHJ3316	<G>	THERMISTOR (I)		1	1	1	1	1	1	1	1	
9	KIEPE2354	<G>	PLUG CORD ASSY		1	1	1	1	1	1	1	1	
10	KIEHJ3362	<G>	REED SWITCH		1	1	1	1	1	1	1	1	
11	KIEP89364	<G>	WATER PIPE ASSY		1	1	1	1	1	1	1	1	
12	KIELR4346	<G>	RUNNING CAPACITOR	4μF 400VAC	1	1	1	1	1	1	1	1	
13	KIEKA0374	<G>	BUZZER BOARD & THERMISTOR (A.T.)		1	1	1	1	1	1	1	1	
14	KIEMQ4363	<G>	LAMP SWITCH (R)		1	1	1	1	1	1	1	1	
15	KIEKA0382	<G>	TEMP CONTROL PANEL		1	1	1	1	1	1	1	1	
16	KIEMQ4320	<G>	FAN MOTOR ASSY		1	1	1	1	1	1	1	1	
17	KIEP89537	<G>	HEATER ROOF		1	1	1	1	1	1	1	1	
18	KIEP89392	<G>	DEFROST HEATER		1	1	1	1	1	1	1	1	
19	KIEP89397	<G>	HEATER COVER		1	1	1	1	1	1	1	1	
20	KIEP89538	<G>	DRIP TRAY		1	1	1	1	1	1	1	1	
21	KIERN4339	<G>	REFCON ASSY		1	1	1	1					
	KIERN8339	<G>						1	1	1	1		
22	KIEP89340	<G>	MOTOR PROTECTOR	5TM718MFBYY53	1	1	1	1	1	1	1	1	
23	KIEE76330	<G>	PTC RELAY	PTH7M330MD2	1	1	1	1	1	1	1	1	
24	KIEG05341	<G>	PROTECTOR COVER		1	1	1	1	1	1	1	1	
25	KIEP89325	<G>	OUT FAN MOTOR ASSY		1	1	1	1	1	1	1	1	
26	KIEP89662	<G>	BELL MOUTH M ASSY		1	1	1	1	1	1	1	1	

RECOMMEND PART NO. 1, 3, 5, 6, 8, 13, 15, 18, 21, 22, 23

ACCESSORY AND UNIT PARTS

**MR-C375C-A
MR-C375CL-A**

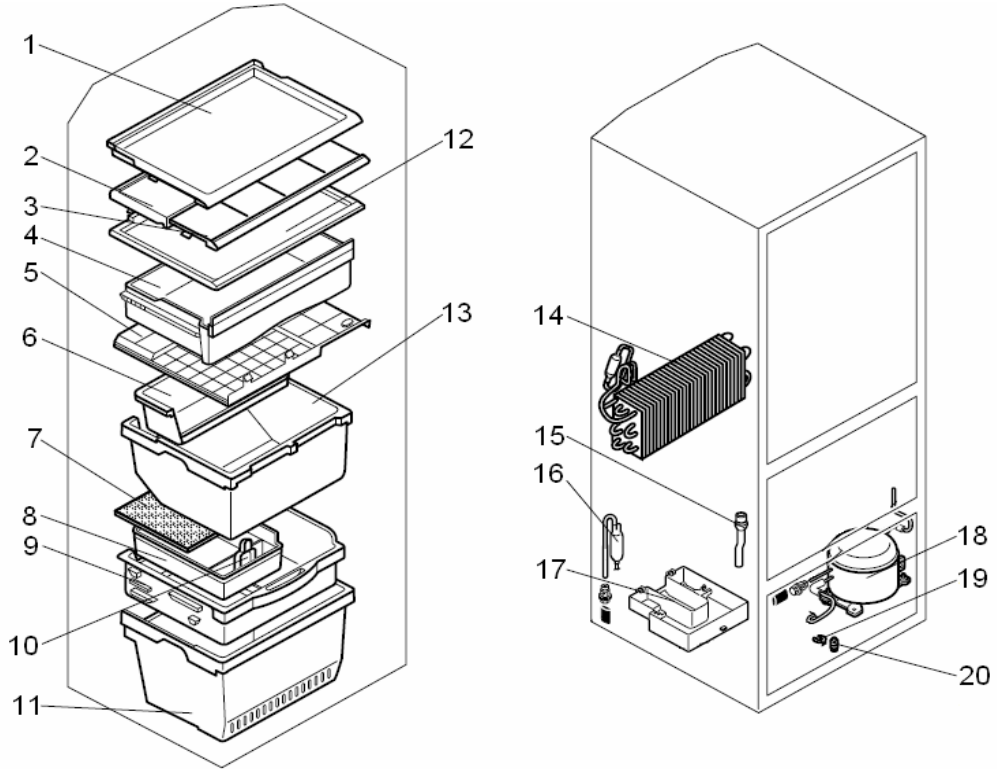

**MR-C405C-A
MR-C405CL-A**

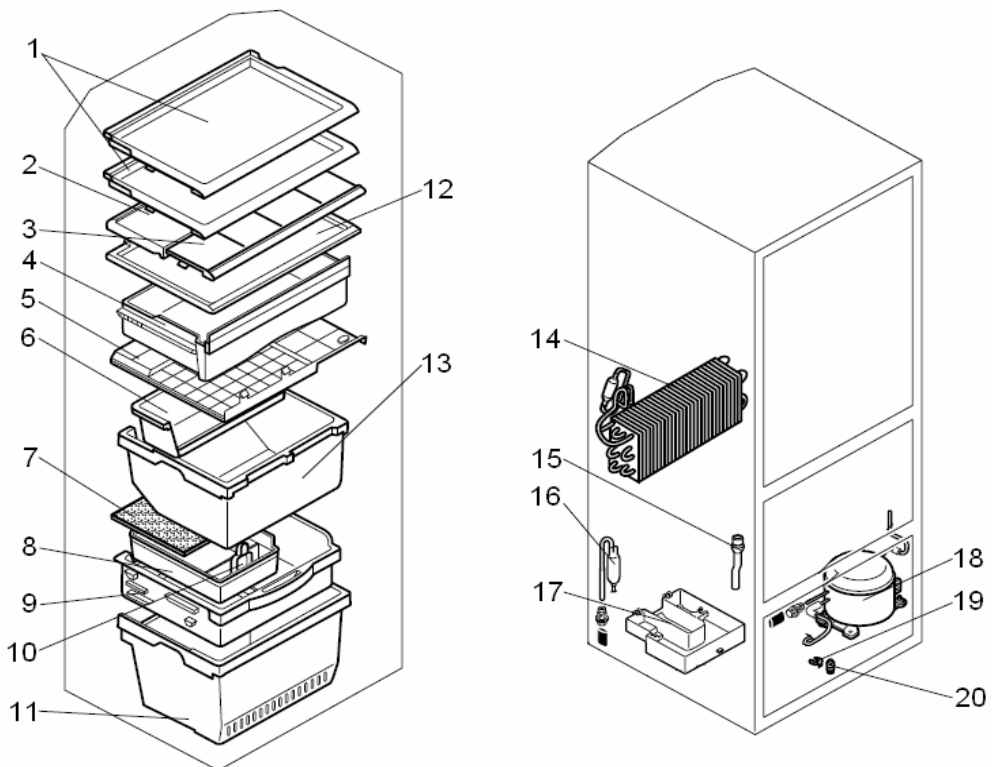

NO.	PART NO.	RoHS	PART NAME	SPEC	Q'TY/UNIT								PRICE/PIECE(US\$-FOB)
					MR-C375C-A		MR-C375CL-A		MR-C405C-A		MR-C405CL-A		
					W	ST	W	ST	W	ST	W	ST	
1	KIEP89420	<G>	GLASS SHELF R ASSY		1	1	1	1	2	2	2	2	
2	KIEHJ3427	<G>	SLIDE SHELF (REAR)		1	1	1	1	1	1	1	1	
3	KIEHJ3428	<G>	SLIDE SHELF (FRONT)		1	1	1	1	1	1	1	1	
4	KIEP89413	<G>	SLIDE CHILLED CASE		1	1	1	1	1	1	1	1	
5	KIEP89409	<G>	VEGEATABLE CASE COVER		1	1	1	1	1	1	1	1	
6	KIEP89406	<G>	FRUIT CASE		1	1	1	1	1	1	1	1	
7	KIEP89468	<G>	ICE BOX SHEET		1	1	1	1	1	1	1	1	
8	KIEP89487	<G>	ICE BOX		1	1	1	1	1	1	1	1	
9	KIEP89474	<G>	FREEZING CASE (UP)		1	1	1	1	1	1	1	1	
10	KIEHJ3477	<G>	ICE SPOON		1	1	1	1	1	1	1	1	
11	KIEP89475	<G>	F CASE (LOW)		1	1	1	1	1	1	1	1	
12	KIEP89420	<G>	GLASS SHELF R ASSY		1	1	1	1	1	1	1	1	
13	KIEP89405	<G>	VEGEATABLE CASE		1	1	1	1	1	1	1	1	
14	KIEP89995	<G>	EVAPORATOR		1	1	1	1	1	1	1	1	
15	KIEP89504	<G>	ELBOW		1	1	1	1	1	1	1	1	
16	KIEAA1980	<G>	DRYER	XH-9,10GR	1	1	1	1	1	1	1	1	
17	KIEP89435	<G>	DRAIN PAN		1	1	1	1	1	1	1	1	
18	KIEPE2277	<G>	COMPRESSOR	DHS66C10RAW	1	1	1	1	1	1	1	1	
19	KIEHJ3735	<G>	U WASHER		4	4	4	4	4	4	4	4	
20	KIEE76797	<G>	RUBBER MOUTH		4	4	4	4	4	4	4	4	

RECOMMEND PART NO. 1, 2, 3, 4, 14, 16, 18

PACKING PARTS

MR-C375C-A

MR-C375CL-A

MR-C405C-A

MR-C405CL-A

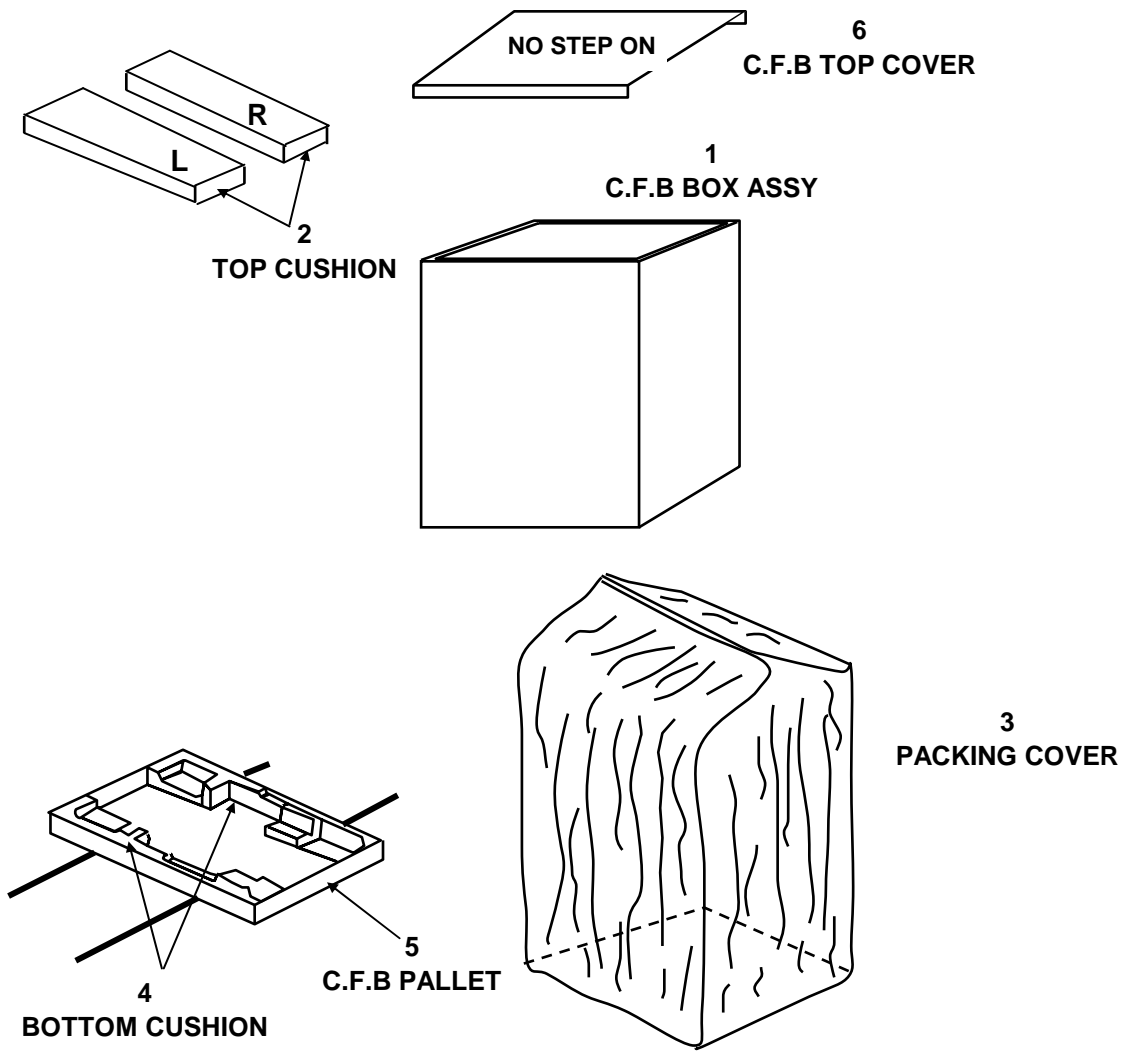

NO.	PART NO.	RoHS	PART NAME	SPEC	Q'TY/UNIT								PRICE/PIECE(US\$-FOB)
					MR-C375C-A		MR-C375CL-A		MR-C405C-A		MR-C405CL-A		
					W	ST	W	ST	W	ST	W	ST	
1	KIERN4970	<G>	C.F.B BOX ASSY		1								
	KIERN5970	<G>				1							
	KIERN6970	<G>					1						
	KIERN7970	<G>						1					
	KIERN8970	<G>							1				
	KIERN9970	<G>								1			
	KIERP0970	<G>									1		
	KIERP1970	<G>										1	
2	KIEP89979	<G>	TOP CUSHION		1	1	1	1	1	1	1	1	
3	KIEHN8973	<G>	PACKING COVER		1	1	1	1	1	1	1	1	
4	KIEP89978	<G>	BOTTOM CUSHION		1	1	1	1	1	1	1	1	
5	KIEP89974	<G>	C.F.B PALLET		1	1	1	1	1	1	1	1	
6	KIEP89975	<G>	C.F.B TOP COVER		1	1	1	1	1	1	1	1	



MITSUBISHI ELECTRIC CORPORATION

HEAD OFFICE : MITSUBISHI DENKI BLDG., MARUNOUCHI, TOKYO 100. TELEX : J24532 CABLE MELCO TOKYO

Distributed by

MITSUBISHI ELECTRIC AUSTRALIA PTY LTD.

(Incorporated in New South Wales) ABN 58 001 215 792

New South Wales :
348 Victoria Road,
Rydalmere NSW 2116
Ph : (02) 9684 7777
Fax : (02) 9898 1043

Queensland:
Unit 12, 469
Nudgee Road,
Hendra QLD , 4011
Ph : (07) 3263 2000
Fax : (07) 3630 1888

South Australia /
Northern territory :
Suite 1, 224 Glen Osmond Road
FULLARTON SA 5063
Ph: (08) 8338 1001
Fax : (08) 8338 0501

Western Australia :
329 Collier Road,
Bassendean WA 6054
Ph : (08) 9377 3400
Fax : (08) 9377 3499

Victoria / Tasmania :
Building 28, Omnico bus. Park
270 Ferntree Gully Road,
Notting Hill 3168
Ph : (03) 9535 7800
Fax : (03) 9535 7801

Far North
Queensland:
Capricorn Air,
13 Mackley St,
Garbutt 4814
Ph: (07) 4775 5222
Fax : (07) 4775 5303

Distributed by

BLACK DIAMOND TECHNOLOGIES LIMITED (BDT)

Wellington Office (Head Office)
1 Parliament Street
PO Box 30-772
Lower Hutt
Ph : (04) 560 9100
Fax : (04) 560 9133

Auckland Office
Unit1, 4 Walls Road
Penrose
Auckland PO Box 12-726
Ph: (09) 526 9340
Fax : (09) 526 9369

Christchurch Office
Suite 2, Level 1
37 Manderville Street
Christchurch PO Box 1604
Ph : (03) 341 7052
Fax : (03) 341 7054