



mitsubishi
ELECTRIC

Changes for the Better

HOME REFRIGERATORS

SERVICE MANUAL

2010

NO.SM-RE-1008

Models MR-BF290B-W-A
MR-BF290B-ST-A
MR-BF325B-W-A
MR-BF325B-ST-A
MR-BF390B-W-A
MR-BF390B-ST-A

CONTENTS

1. SPECIFICATIONS.....	1
2. OUTLINES AND DIMENSIONS.....	7
3. WIRING DIAGRAM.....	10
4. REFRIGERANT CIRCUIT.....	12
5. NAMES OF THE PARTS.....	13
6. TROUBLE SHOOTING.....	14
6.1 TROUBLE CRITERION OF MAIN PARTS.....	14
6.2 TEST POINT DIAGRAM OF MAIN CONTROL BOARD.....	17
6.3 MULFUNCTION DISPLAY AND CHECKING POINT.....	18
6.4 IMPORTANCE DETAIL OF FAULT ANALYSIS.	19
7. DISASSEMBLY INSTRUCTIONS.....	20
8. PARTS LIST.....	24

A.....Australia & New Zea land

1

SPECIFICATIONS

1-1 SPECIFICATIONS

MR-BF290B-A

Power supply		230-240V 50Hz	
Total capacity	L	GROSS (AS) 290 (R : 185 F : 105)	
Dimensions (HXWXD)	mm.	1359 x 600 x 656	
Cabinet		Acrylic resin coated steel	
Food liner		ABS resin	
Insulation	Cabinet	Foamed cyclopentane	
	Refrigerator door	Foamed cyclopentane	
	Vegetable door	Foamed cyclopentane	
	Freezer door	Foamed cyclopentane	
Cooling system	Freezer	Forced air convection	
	Refrigerator	3 way air flow	
Evaporator		Fin and tube type	
Condenser		Concealed type	
Defrost system		Automatic (Defrost heater)	
Drain		Automatic (drainage)	
Temperature control system		Automatic control	
Refrigerator room light		240V, 15W (E12)	
Accessories	Glass shelf (R)		2 pcs.
	Slide shelf		1 pc.
	Slide chilled case		1 pc.
	Free pocket (L)		2 pcs.
	Egg case		1 pc.
	Bottle pocket		1 pc.
	Bottle stopper		1 pc.
	Ice tray		1 pc.
	Ice box		1 pc.
	Freezing case (UP)		1 pc.
	Freezing case (LOW)		1 pc.
	Kick plate		1 pc.
Weight	Unit	kg	60
	Shipping	kg	67

MR-BF325B-A

Power supply		230-240V 50Hz	
Total capacity	L	GROSS (AS) 325 (R : 220 F : 105)	
Dimensions (HXWXD)	mm.	1479 x 600 x 656	
Cabinet		Acrylic resin coated steel	
Food liner		ABS resin	
Insulation	Cabinet	Foamed cyclopentane	
	Refrigerator door	Foamed cyclopentane	
	Vegetable door	Foamed cyclopentane	
	Freezer door	Foamed cyclopentane	
Cooling system	Freezer	Forced air convection	
	Refrigerator	3 way air flow	
Evaporator		Fin and tube type	
Condenser		Concealed type	
Defrost system		Automatic (Defrost heater)	
Drain		Automatic (drainage)	
Temperature control system		Automatic control	
Refrigerator room light		240V, 15W (E12)	
Accessories	Glass shelf (R)	3 pcs.	
	Slide shelf	1 pc.	
	Slide chilled case	1 pc.	
	Free pocket (L)	2 pcs.	
	Egg case	1 pc.	
	Free pocket (S)	1 pc.	
	Bottle pocket	1 pc.	
	Bottle stopper	1 pc.	
	Ice tray	1 pc.	
	Ice box	1 pc.	
	Freezing case (UP)	1 pc.	
	Freezing case (LOW)	1 pc.	
	Kick plate	1 pc.	
Weight	Unit	kg	64
	Shipping	kg	70

MR-BF390B-A

Power supply			230-240V 50Hz
Total capacity		L	GROSS (AS) 390 (R : 285 F : 105)
Dimensions (HXWXD)		mm.	1720 x 600 x 656
Cabinet			Acrylic resin coated steel
Food liner			ABS resin
Insulation	Cabinet		Foamed cyclopentane
	Refrigerator door		Foamed cyclopentane
	Vegetable door		Foamed cyclopentane
	Freezer door		Foamed cyclopentane
Cooling system	Freezer		Forced air convection
	Refrigerator		3 way air flow
Evaporator			Fin and tube type
Condenser			Concealed type
Defrost system			Automatic (Defrost heater)
Drain			Automatic (drainage)
Temperature control system			Automatic control
Refrigerator room light			240V, 15W (E12)
Accessories	Glass shelf (R)		4 pcs.
	Slide shelf		1 pc.
	Slide chilled case		1 pc.
	Free pocket (L)		2 pcs.
	Egg case		1 pc.
	Free pocket (S)		1 pc.
	Bottle pocket		2 pcs.
	Bottle stopper		1 pc.
	Ice tray		1 pc.
	Ice box		1 pc.
	Freezing case (UP)		1 pc.
	Freezing case (LOW)		1 pc.
	Kick plate		1 pc.
Weight	Unit	kg	70
	Shipping	kg	77

1-2 ELECTRICAL PARTS SPECIFICATION

MR-BF290B-A

Compressor	Model		DHS66C10RAW			
	Power supply		220-240V, 50Hz			
	Rated input	W	113/113.5(220/240V 50Hz)			
	Starting current	A	7.78/8.55(220/240V 50Hz)			
	Running current	A	0.70/0.64(220/240V 50Hz)			
	Winding resistance (A.T. 20 °C)		18.4 Ω(Main) / 18.5 Ω(Aux)			
PTC RELAY			PTH7M330MD2			
Motor protector	Model		5TM222NFBYY-53			
	Ambient temperature	°C	25			
	Time	Sec.	16 MAX			
	Current	A	6.7			
Running capacitor			4μF 400VAC			
Capillary tube		mm.	∅ 1.8 X ∅ 0.6 X 2350			
Dehydrant Molecular sieve		g	10			
Refrigerant HFC. 134a		g	170			
Defrosting control	Defrosting timer		Control board			
	Defrost finish	°C	Thermister 14 ± 1.5			
	Thermal fuse	°C	73			
	Defrost heater		372 Ω (240V, 150W)			
	Deodorizing function of defrost heater		Not equipped			
Fan motor	Refrigerator	Model		FBA12J12VXC		
		Type		DC brushless		
		Rate Voltage		12VDC		
		Input	W	4.2 (12 VDC)		
		Revolution	r.p.m	2300 (12 VDC)		
Heater		Vegetable case heater	W	6		
Temperature control			Thermistor F		Thermistor R	
			Freezer		Refrigerator	
	Dial position		ON	OFF	OPEN	SHUT
	LOW	°C	-12.3	-18.4	6.1	4.2
	MID	°C	-16.8	-22.7	3.2	1.3
HI	°C	-18.7	-24.6	0.7	-1.2	

MR-BF325B-A

Compressor	Model		DHS66C10RAW			
	Power supply		220-240V, 50Hz			
	Rated input	W	113/113.5(220/240V 50Hz)			
	Starting current	A	7.78/8.55(220/240V 50Hz)			
	Running current	A	0.70/0.64(220/240V 50Hz)			
	Winding resistance (A.T. 20 °C)		18.4 Ω(Main) / 18.5 Ω(Aux)			
PTC RELAY			PTH7M330MD2			
Motor protector	Model		5TM222NFBYY-53			
	Ambient temperature	°C	25			
	Time	Sec.	16 MAX			
	Current	A	6.7			
Running capacitor			4μF 400VAC			
Capillary tube		mm.	∅ 1.8 X ∅ 0.6 X 2350			
Dehydrant Molecular sieve		g	10			
Refrigerant HFC. 134a		g	170			
Defrosting control	Defrosting timer		Control board			
	Defrost finish	°C	Thermister 14 ± 1.5			
	Thermal fuse	°C	73			
	Defrost heater		372 Ω (240V, 150W)			
	Deodorizing function of defrost heater		Not equipped			
Fan motor	Refrigerator	Model		FBA12J12VXC		
		Type		DC brushless		
		Rate Voltage		12VDC		
		Input	W	4.2 (12 VDC)		
		Revolution	r.p.m	2300 (12 VDC)		
Heater		Vegetable case heater	W	6		
Temperature control			Thermistor F		Thermistor R	
			Freezer		Refrigerator	
	Dial position		ON	OFF	OPEN	SHUT
	LOW	°C	-10.8	-18.4	6.7	4.8
	MID	°C	-15.4	-22.7	3.8	1.9
HI	°C	-17.3	-24.6	1.3	-0.6	

MR-BF390B-A

Compressor	Model		DHS66C10RAW			
	Power supply		220-240V, 50Hz			
	Rated input	W	113/113.5(220/240V 50Hz)			
	Starting current	A	7.78/8.55(220/240V 50Hz)			
	Running current	A	0.70/0.64(220/240V 50Hz)			
	Winding resistance (A.T. 20 °C)		18.4 Ω(Main) / 18.5 Ω(Aux)			
PTC RELAY			PTH7M330MD2			
Motor protector	Model		5TM222NFBYY-53			
	Ambient temperature	°C	25			
	Time	Sec.	16 MAX			
	Current	A	6.7			
Running capacitor			4μF 400VAC			
Capillary tube		mm.	∅ 1.8 X ∅ 0.6 X 2350			
Dehydrant Molecular sieve		g	10			
Refrigerant HFC. 134a		g	170			
Defrosting control	Defrosting timer		Control board			
	Defrost finish	°C	Thermister 14 ± 1.5			
	Thermal fuse	°C	73			
	Defrost heater		372 Ω (240V, 150W)			
	Deodorizing function of defrost heater		Not equipped			
Fan motor	Refrigerator	Model		FBA12J12VXC		
		Type		DC brushless		
		Rate Voltage		12VDC		
		Input	W	4.2 (12 VDC)		
		Revolution	r.p.m	2300 (12 VDC)		
Heater		Vegetable case heater	W	6		
Temperature control			Thermistor F		Thermistor R	
			Freezer		Refrigerator	
	Dial position		ON	OFF	OPEN	SHUT
	LOW	°C	-10.8	-18.4	6.7	4.8
	MID	°C	-15.4	-22.7	3.8	1.9
HI	°C	-17.3	-24.6	1.3	-0.6	

MR-BF290B-A

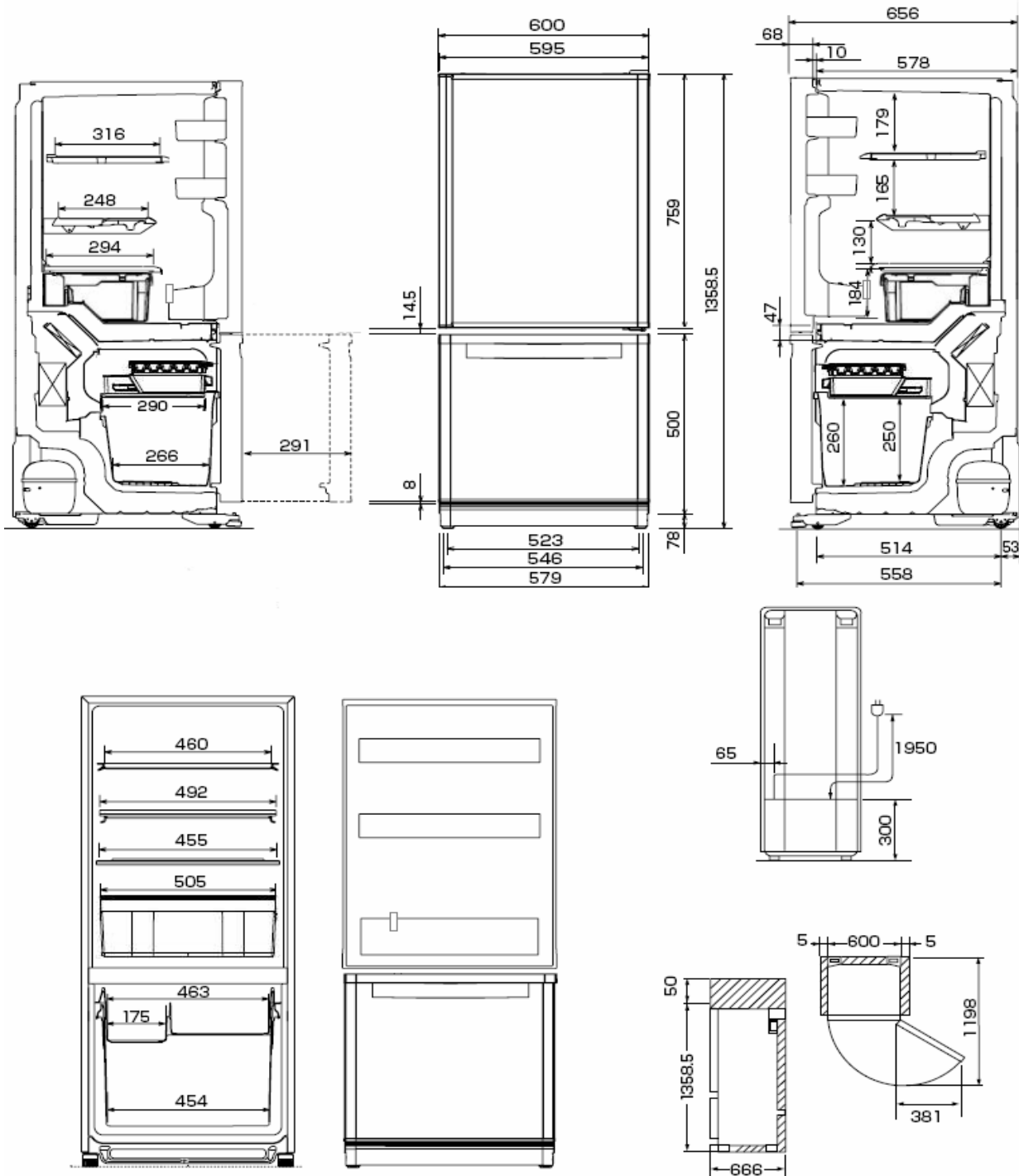

2

OUTLINES AND DIMENSIONS

Unit : mm

MR-BF325B-A

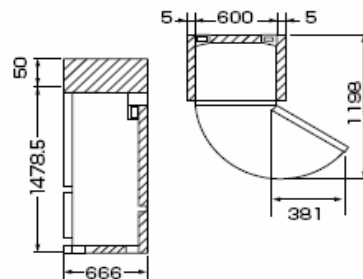
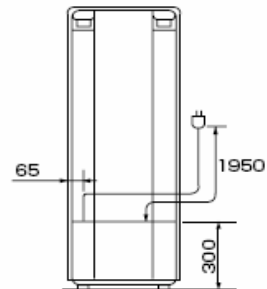
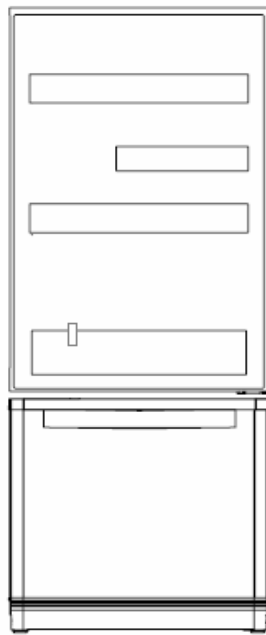
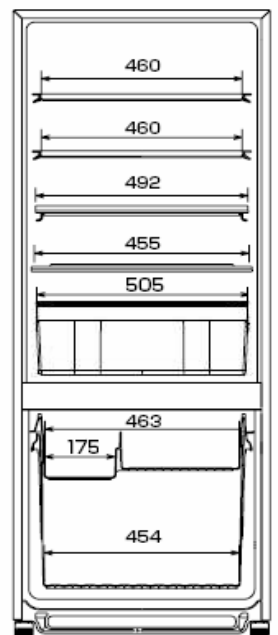
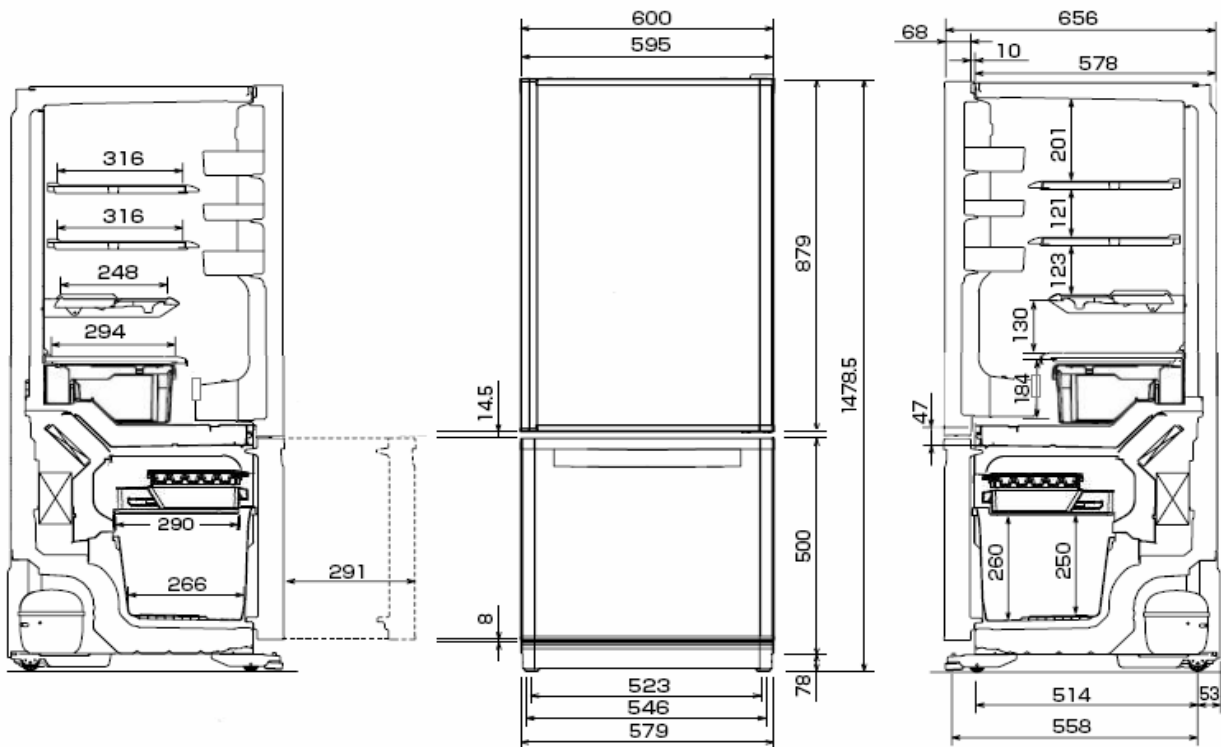

2

OUTLINES AND DIMENSIONS

Unit : mm

MR-BF390B-A

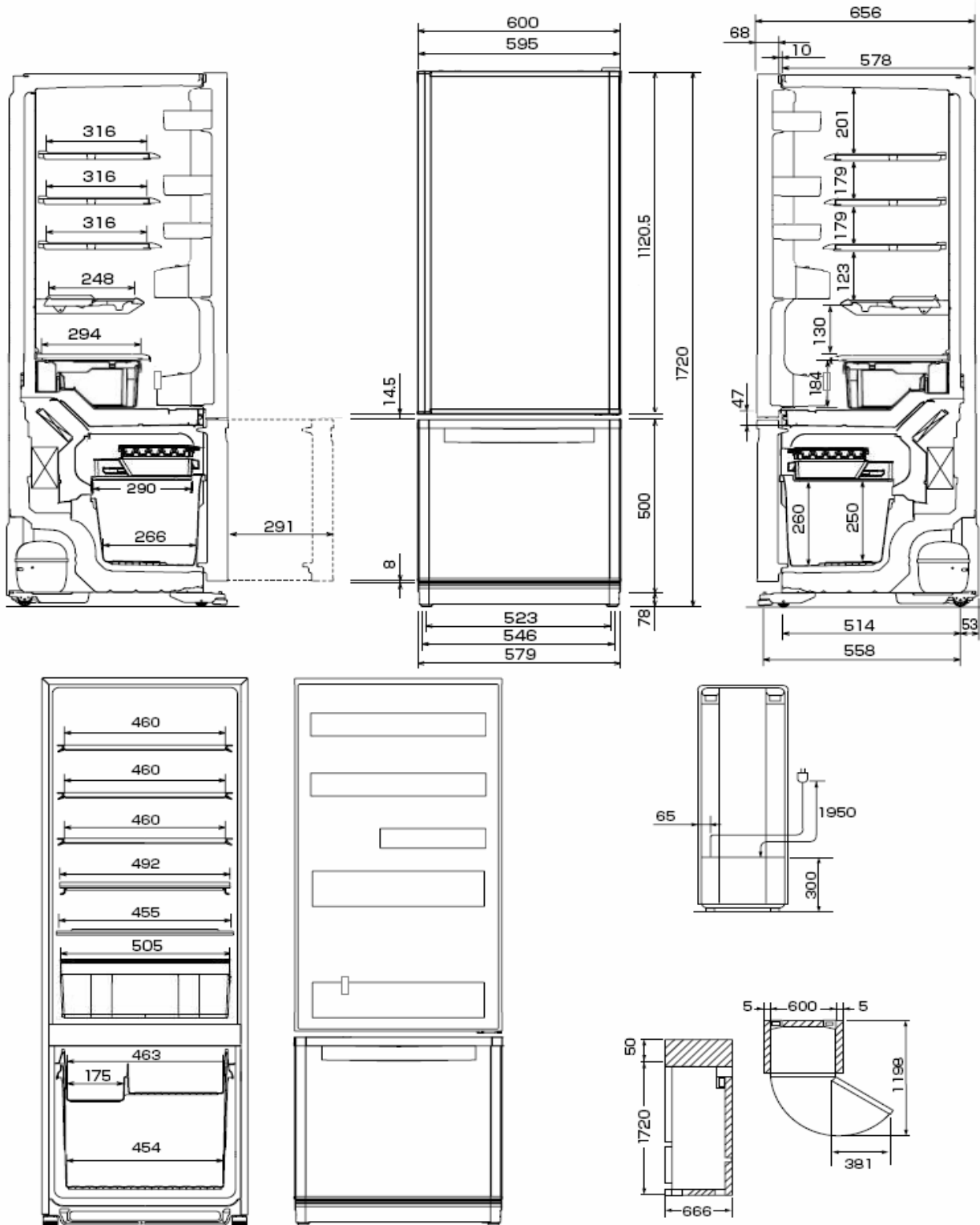

3

WIRING DIAGRAM

(SKELETON WIRING DIAGRAM)

MR-BF290B-A
 MR-BF325B-A
 MR-BF390B-A

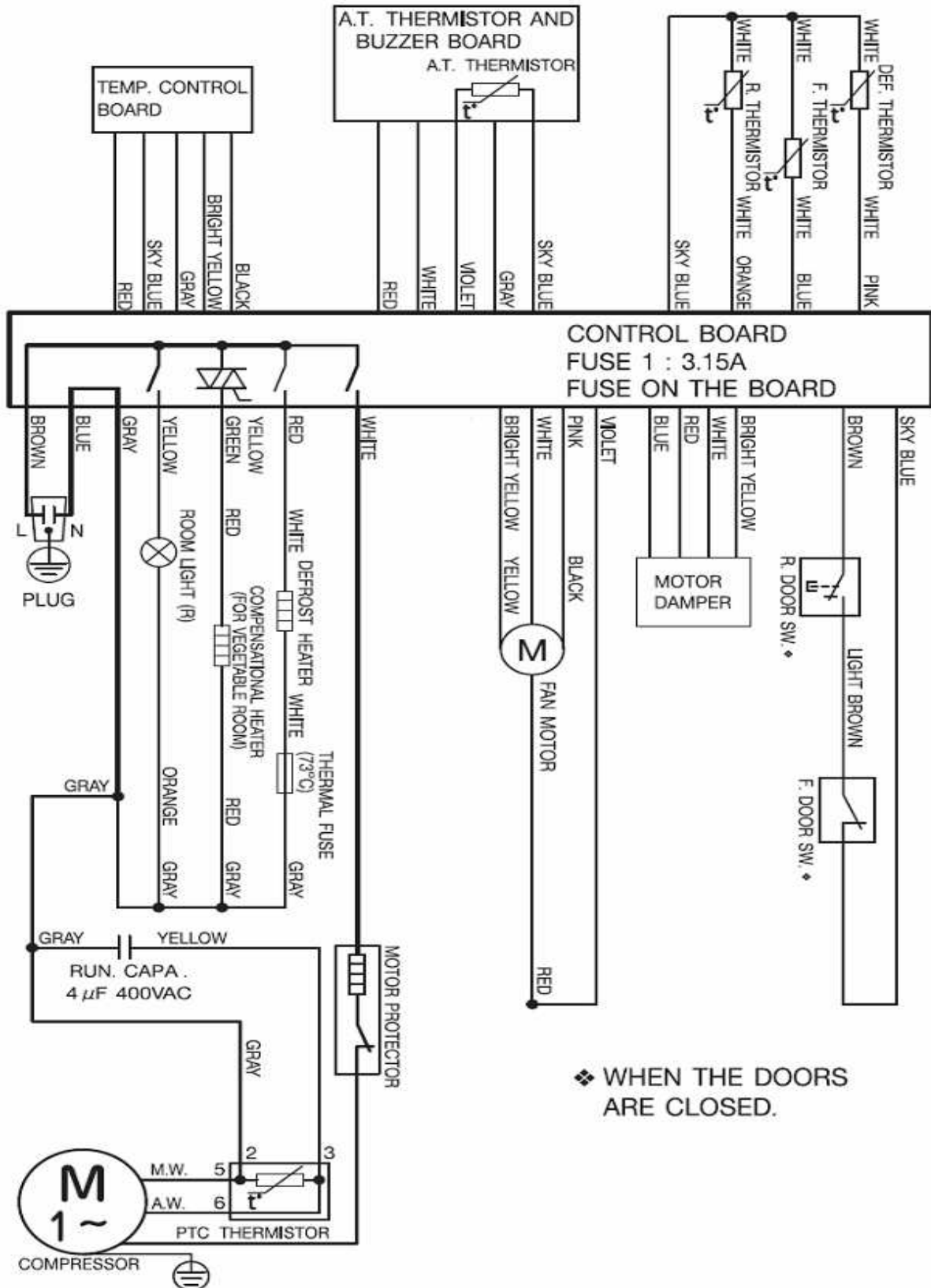

(ACTUAL WIRING DIAGRAM)

MR-BF290B-A MR-BF325B-A MR-BF390B-A

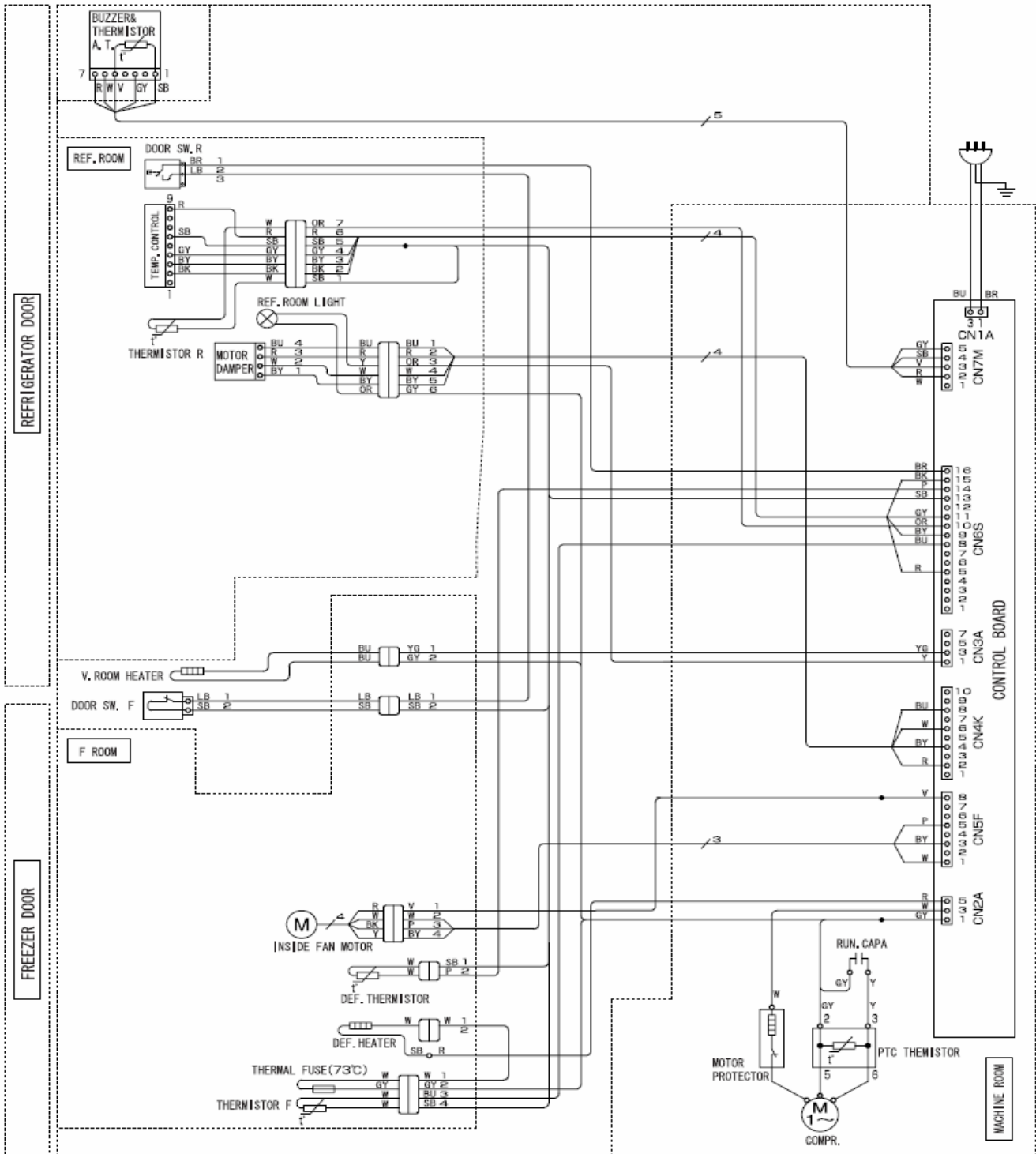

- | | | | |
|---------------|------------------|--------------------|------------|
| Remark | GY = GRAY | BK = BLACK | BR = BROWN |
| | W = WHITE | OR = ORANGE | |
| | R = RED | Y = YELLOW | |
| | SB = SKY BLUE | YG = YELLOW/GREEN | |
| | P = PINK | LG = LIGHT GREEN | |
| | LB = LIGHT BROWN | BY = BRIGHT YELLOW | |
| | V = VIOLET | BU = BLUE | |

4

REFRIGERANT CIRCUIT

MR-BF290B-A
MR-BF325B-A
MR-BF390B-A

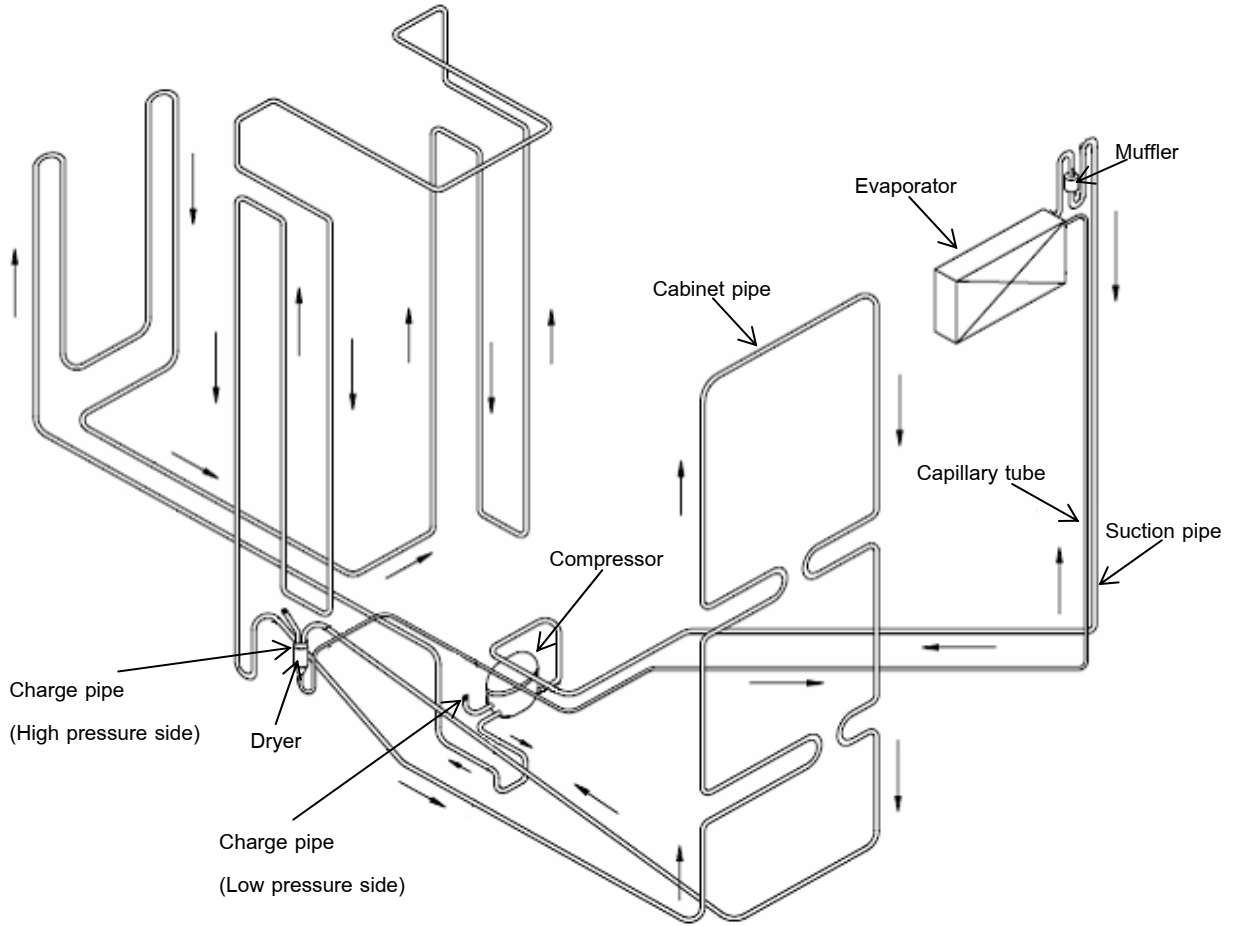

MR-BF290B-A
 MR-BF325B-A
 MR-BF390B-A

Refrigerator Compartment

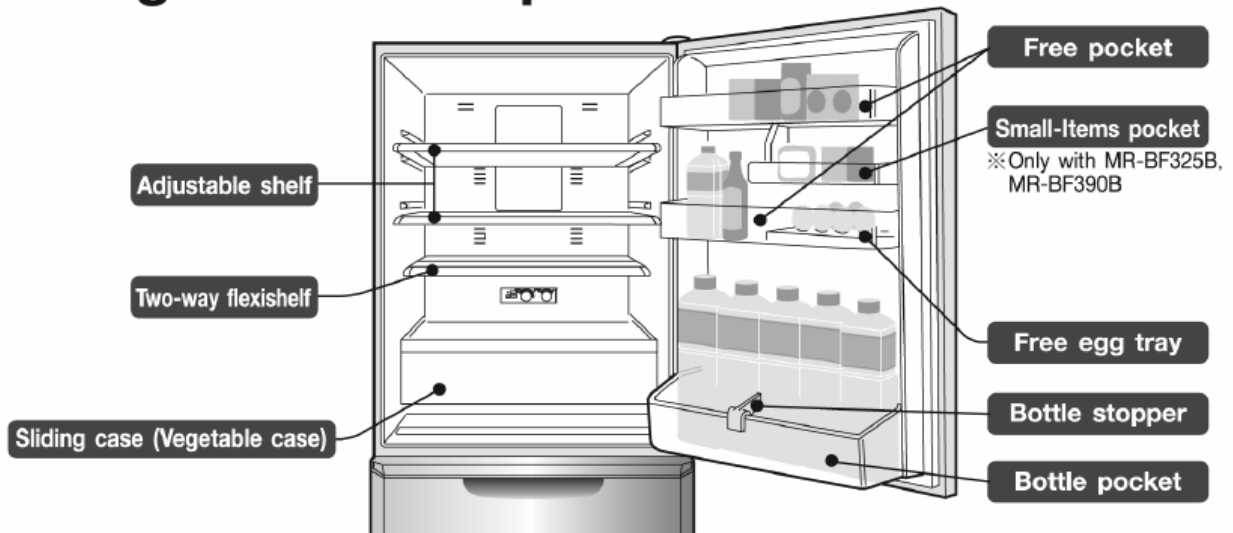

Freezer Compartment

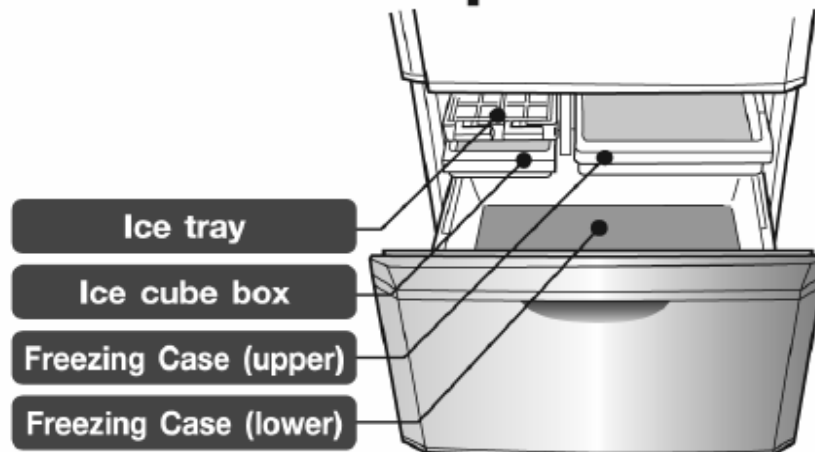

6

TROUBLE SHOOTING

6.1 TROUBLE CRITERION OF MAIN PARTS

MR-BF290B-A

MR-BF325B-A

MR-BF390B-A

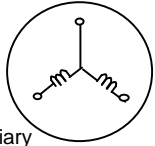
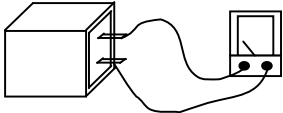
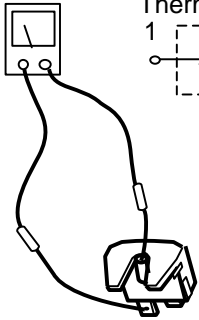
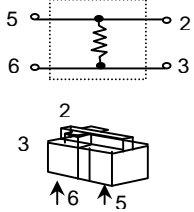
Components / Part Name	Check Method and Criterion	Parts Mounted Position																					
Compressor	<table border="1" data-bbox="296 539 1094 707"> <tr> <td colspan="2">Model</td> <td>DHS66C10RAW</td> </tr> <tr> <td>Rated input</td> <td>W</td> <td>113/113.5(220/240V 50Hz)</td> </tr> <tr> <td>Starting current</td> <td>A</td> <td>7.78./8.55(220/240V 50Hz)</td> </tr> <tr> <td>Running current</td> <td>A</td> <td>0.52/0.48(220/240V 50Hz)</td> </tr> </table> <table border="1" data-bbox="520 714 1246 958"> <tr> <td></td> <td>Normal</td> <td>Abnormal (faulty)</td> </tr> <tr> <td>Main wiring</td> <td>18.4 Ω (Approx.)</td> <td>Opened (∞ Ω) or Short (0Ω)</td> </tr> <tr> <td>Auxilliary wiring</td> <td>18.5 Ω (Approx.)</td> <td></td> </tr> </table>  <p>Auxiliary wiring Main wiring</p> <p>Measure the resistance with a tester. (Ambient temperature:Room temperature 15°C ~ 25°C)</p>	Model		DHS66C10RAW	Rated input	W	113/113.5(220/240V 50Hz)	Starting current	A	7.78./8.55(220/240V 50Hz)	Running current	A	0.52/0.48(220/240V 50Hz)		Normal	Abnormal (faulty)	Main wiring	18.4 Ω (Approx.)	Opened (∞ Ω) or Short (0Ω)	Auxilliary wiring	18.5 Ω (Approx.)		Compressor in the machine chamber at the rear side of the frame
Model		DHS66C10RAW																					
Rated input	W	113/113.5(220/240V 50Hz)																					
Starting current	A	7.78./8.55(220/240V 50Hz)																					
Running current	A	0.52/0.48(220/240V 50Hz)																					
	Normal	Abnormal (faulty)																					
Main wiring	18.4 Ω (Approx.)	Opened (∞ Ω) or Short (0Ω)																					
Auxilliary wiring	18.5 Ω (Approx.)																						
Run capacitor	 <table border="1" data-bbox="719 1155 1094 1200"> <tr> <td>Rated input</td> <td>400VAC</td> </tr> </table> <p>Measure the resistance with a tester.</p> <table border="1" data-bbox="719 1256 1126 1346"> <tr> <td>Normal</td> <td>Abnormal(faulty)</td> </tr> <tr> <td>4 μF</td> <td>Short (0Ω)</td> </tr> </table>	Rated input	400VAC	Normal	Abnormal(faulty)	4 μF	Short (0Ω)	In the control panel of the rear side at compressor room															
Rated input	400VAC																						
Normal	Abnormal(faulty)																						
4 μF	Short (0Ω)																						
Motor protector	 <p>Therminal check point</p> <table border="1" data-bbox="719 1420 1126 1547"> <tr> <td>Model</td> <td colspan="2">5TM222NFBYY-53</td> </tr> <tr> <td rowspan="2">Connected Point</td> <td>Open</td> <td>120 ± 5° C</td> </tr> <tr> <td>Close</td> <td>69 ± 9° C</td> </tr> </table> <p>Measure the resistance with a tester.(Ambient temperature:Room temperature 15°C ~ 25°C)</p> <table border="1" data-bbox="783 1630 1150 1720"> <tr> <td>Normal</td> <td>Abnormal(faulty)</td> </tr> <tr> <td>Less than 1Ω</td> <td>Opened (∞ Ω)</td> </tr> </table>	Model	5TM222NFBYY-53		Connected Point	Open	120 ± 5° C	Close	69 ± 9° C	Normal	Abnormal(faulty)	Less than 1Ω	Opened (∞ Ω)	Compressor in the machine chamber at the rear side of the frame									
Model	5TM222NFBYY-53																						
Connected Point	Open	120 ± 5° C																					
	Close	69 ± 9° C																					
Normal	Abnormal(faulty)																						
Less than 1Ω	Opened (∞ Ω)																						
PTC Relay	 <table border="1" data-bbox="568 1794 1214 1839"> <tr> <td>Model</td> <td>PTH7M330MD2</td> </tr> </table> <p>Measure the resistance with a tester. (Ambient temperature:Room temperature 15°C ~ 25°C)</p> <table border="1" data-bbox="568 1928 1182 2018"> <tr> <td>Normal</td> <td>Abnormal(faulty)</td> </tr> <tr> <td>33 Ω (Approx.)</td> <td>Opened (∞ Ω) or Short (0Ω)</td> </tr> </table> <p>As PTC Relay has been heated while refrigerator is running be sure to measure the resistance after the thermistor has got cool enough.</p>	Model	PTH7M330MD2	Normal	Abnormal(faulty)	33 Ω (Approx.)	Opened (∞ Ω) or Short (0Ω)	Compressor in the machine chamber at the rear side of the frame															
Model	PTH7M330MD2																						
Normal	Abnormal(faulty)																						
33 Ω (Approx.)	Opened (∞ Ω) or Short (0Ω)																						

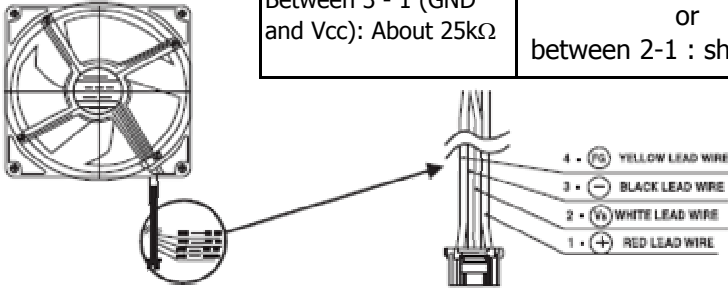
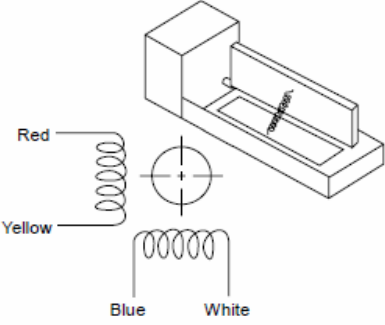
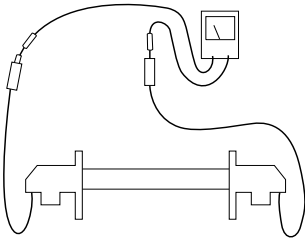
Components/ Part Name	Check Method and Criterion	Parts Mounted Position								
Refrigerator fan motor	<table border="1" data-bbox="711 322 1193 412"> <tr> <td>Model</td> <td>FBA12J12VXC</td> </tr> <tr> <td>Type</td> <td>DC brushless</td> </tr> </table> <p data-bbox="312 421 1184 452">Measure the resistance with a tester.(Ambient temperature:Room temperature 15°C ~ 25°C)</p> <table border="1" data-bbox="603 456 1193 618"> <tr> <th>Normal</th> <th>Abnormal (faulty)</th> </tr> <tr> <td>Between 3 - 1 (GND and Vcc): About 25kΩ</td> <td>Between 3-1 : open(∞ Ω) or between 2-1 : short (0 Ω)</td> </tr> </table> 	Model	FBA12J12VXC	Type	DC brushless	Normal	Abnormal (faulty)	Between 3 - 1 (GND and Vcc): About 25kΩ	Between 3-1 : open(∞ Ω) or between 2-1 : short (0 Ω)	In the fan grille of the refrigerator compartment.
Model	FBA12J12VXC									
Type	DC brushless									
Normal	Abnormal (faulty)									
Between 3 - 1 (GND and Vcc): About 25kΩ	Between 3-1 : open(∞ Ω) or between 2-1 : short (0 Ω)									
Motor damper for refrigerator compartment/ slide compartment	<p data-bbox="312 878 1184 909">Measure the resistance with a tester.(Ambient temperature:Room temperature 15°C ~ 25°C)</p>  <table border="1" data-bbox="711 927 1193 1128"> <tr> <td></td> <th>Normal</th> <th>Abnormal (faulty)</th> </tr> <tr> <th>Winding (Blue-White, Red-Yellow)</th> <td>415 Ω (Approx.)</td> <td>Open (∞ Ω) or short circuit (0Ω)</td> </tr> </table>		Normal	Abnormal (faulty)	Winding (Blue-White, Red-Yellow)	415 Ω (Approx.)	Open (∞ Ω) or short circuit (0Ω)	In the fan grille of the refrigerator compartment.		
	Normal	Abnormal (faulty)								
Winding (Blue-White, Red-Yellow)	415 Ω (Approx.)	Open (∞ Ω) or short circuit (0Ω)								
Defrost Heater	 <table border="1" data-bbox="676 1285 1155 1402"> <tr> <td>Rated input</td> <td>155 W</td> </tr> <tr> <td>operation method</td> <td>Power ON after defrosting (14 ± 1.5°C or more)</td> </tr> </table> <p data-bbox="679 1411 1203 1482">Measure the resistance with a tester. (Ambient temperature:Room temperature 15°C ~ 25°C)</p> <table border="1" data-bbox="641 1500 1193 1612"> <tr> <th>Normal</th> <th>Abnormal (faulty)</th> </tr> <tr> <td>372Ω (Approx.)</td> <td>Opened (∞ Ω)</td> </tr> </table>	Rated input	155 W	operation method	Power ON after defrosting (14 ± 1.5°C or more)	Normal	Abnormal (faulty)	372Ω (Approx.)	Opened (∞ Ω)	In the drip tray under the evaporator of the freezer compartment
Rated input	155 W									
operation method	Power ON after defrosting (14 ± 1.5°C or more)									
Normal	Abnormal (faulty)									
372Ω (Approx.)	Opened (∞ Ω)									

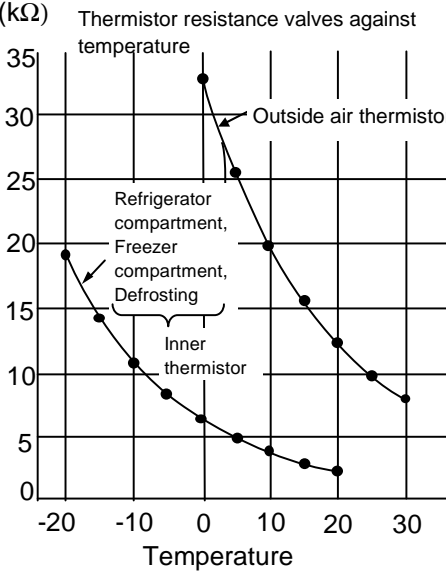
Components/ Part Name	Check Method and Criterion	Parts Mounted Position
Thermistor	<p>Measure the resistance with a tester according to the following graph. (Thermistor resistance values against temperature)</p> <ul style="list-style-type: none"> Resistance measured under the ambient temperature from -50°C to +50 °C <ol style="list-style-type: none"> 200 Ω to 500kΩnormal Out of the above rangeabnormal <p>(kΩ) Thermistor resistance values against temperature</p>  <p>Thermistor Check Procedure</p> <ul style="list-style-type: none"> Thermistor resistance value will vary with the change of temperature. Take the temperature around the thermistor, and then measure thermistor resistance using a tester. <p>The relation between resistance and temperature is as shown on the left side.</p> <p>Trouble shooting with self-check</p> <ol style="list-style-type: none"> If the self - check indicates the abnormality of thermistor right after the power is turned on, measure the resistance of the thermistor. <ul style="list-style-type: none"> If the circuit of thermistor is short , check the element of the thermistor and the contact of the connector. When the self - check indicates the abnormality of thermistor a few seconds after the power is turned on , check the contact of the connector. 	<p>(Defrost thermistor) Evaporator</p> <p>(Freezer compartment thermistor) In the fan grille of freezer compartment</p> <p>(Refrigerator compartment thermistor) In the control panel of refrigerator compartment</p> <p>(Outside air thermistor) In the buzzer board (check board)</p>

6.2 TEST POINT DIAGRAM OF MAIN CONTROL BOARD
MR-BF290B-A MR-BF325B-A MR-BF390B-A

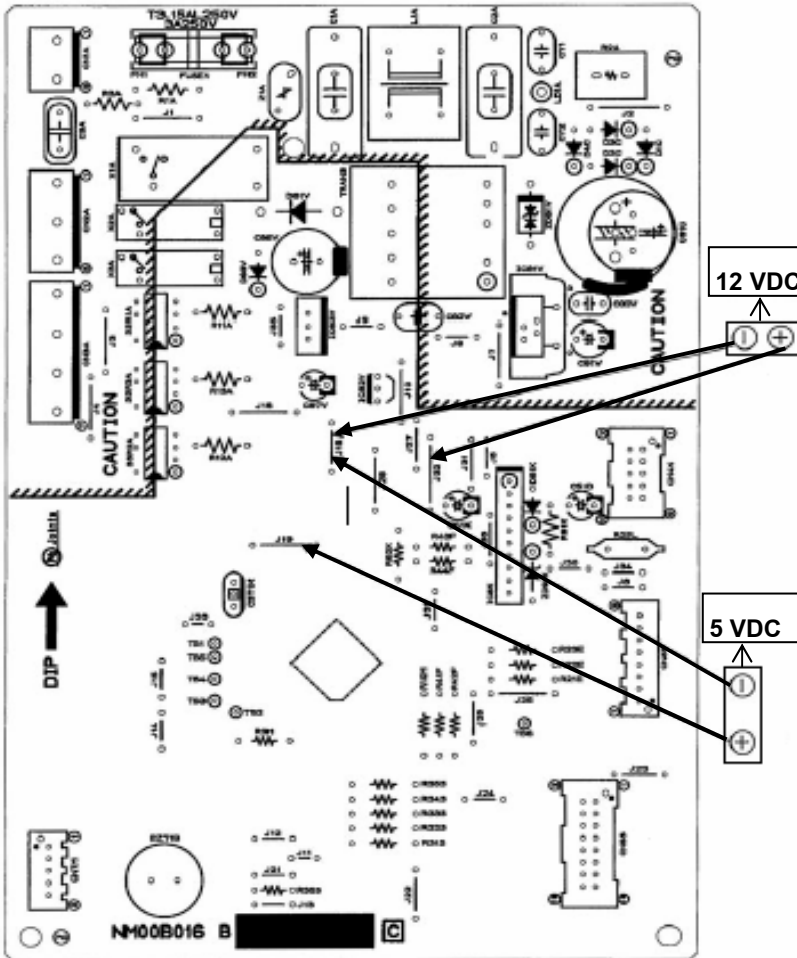

CN4K	Lead color	Parts Name
1		
2	Red	Damper
3		
4	Bright Yellow	Damper
5		
6	White	Damper
7		
8	Blue	Damper
9		
10		

CN5F	Lead color	Parts Name
8	Violet	12 VDC Common
7		
6		
5	Pink	GND
4		
3	Bright Yellow	Inner Fan Motor FG
2		
1	White	Inner Fan Motor Vs

CN6S	Lead color	Parts Name
1		
2		
3		
4		
5	Red	Ice maker Stop LED
6		
7		
8	Blue	F Thermistor
9	Bright Yellow	Temp Control Board
10	Orange	R Thermistor
11	Gray	Temp Control Board
12		
13	Sky Blue	5 VDC Common
14	Pink	DEF Thermistor
15	Black	GND
16	Brown	Door SW

CN1A	Lead color	Parts Name
1	Grey	230 - 240 VAC
3	Black	

CN2A	Lead color	Parts Name
1	Grey	230 - 240 VAC Common
3	White	Compressor
5	Red	Defrost Heater

CN3A	Lead color	Parts Name
1	Yellow	Lamp
3	Yellow/Green	V Heater
5		
7		

CN7M	Lead color	Parts Name
1	White	12 VDC Common
2	Red	Buzzer
3	Violet	A.T. Thermistor
4	Sky Blue	5 VDC Common
5	Grey	Compulsion DEF

Compulsory defrosting method have 2 methods as below

- 1) Short circuit at 2-pin connector between no.6 (white wire) with no.7 (red wire) at Buzzer & Thermistor A.T. board.(Inside hinge cover)
- 2) Open door R and then adjust dial freezer at MID position. Use magnet touch door switch in order to simulate as door closing. (lamp must no light),then turn the dial continuously as follow COLDER → LOW → MID

6.3 LED trouble display and check point.

6.3.1) Trouble is indicated by the blinking number of self-check LED.

6.3.2) LED blinks as shown below.

The blinking number of self-check LED specifies the trouble which has occurred.

LED repeats to blinks as many times as the number specified for each trouble under this cycle :lighted for 0.3 second/not lighted for 0.3 second.

(Example)Malfunction of defrost thermistor

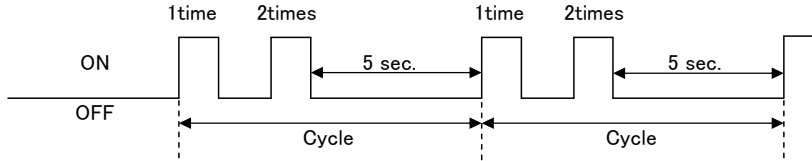

6.3.3) Check point and Repairing

※When several troubles occur,smaller blinking number LED has priority to be indicated first.

Function display		Cause	Analysis	Check point	Corrective	Priority Repairing	
LED display self-check	Malfunction display Lighting mode	1 time	Fault trouble of freezer thermistor	Open circuit or short circuit case	1.Check connector of control PCB CN6S, relay connector 4 pins 2.Check the resistance of thermistor	Improve in contact Change part	1
		2 times	Fault trouble of defrost thermistor	Open circuit or short circuit case	1.Check connector of control PCB CN6S, relay connector 2 pins 2.Check the resistance of thermistor	Improve in contact Change part	2
		3 times	Fault trouble of defrost heater	Defrost unfinished with in 2 hours	1.Check connector of control PCB CN2A, relay connector 1 pin 2.Check the resistance of defrost heater 3.Check the resistance of temp. fuse	Improve in contact Change part Change part	3
		6 times	Fault trouble of A.T. thermistor	Open circuit or short circuit case	1.Check connector of control PCB CN7M, relay connector 7 pins 2.Check the resistance of thermistor	Improve in contact Change part	4
		10 times	Fault trouble of fan motor	Don't rolling case	1.Check connector of control PCB CN5F, relay connector 4 pin 2.Check the movement of fan motor	Improve in contact Change part	5
		16 times	Fault trouble of Memory (Control Board)	Out of control case	—————	Change Control Board	6

Caution

1.Before plug in the AC power, Be ensure the comp had been off more than 20 min.

2.The consider short circuit or open circuit of thermistor, resistance of open circuit is $\infty \Omega$, resistance of short circuit is 0Ω .

6.4 Importance detail of fault analysis

Flow chart of self - check

1) Self - check monitor circuit

For show the fault condition of refrigerator and clarify point. Therefore, self - check monitor control is provided that are able to monitor No. of blinking condition with electric circuit and electric part . Before disconnect power plug please confirm LED self - check .

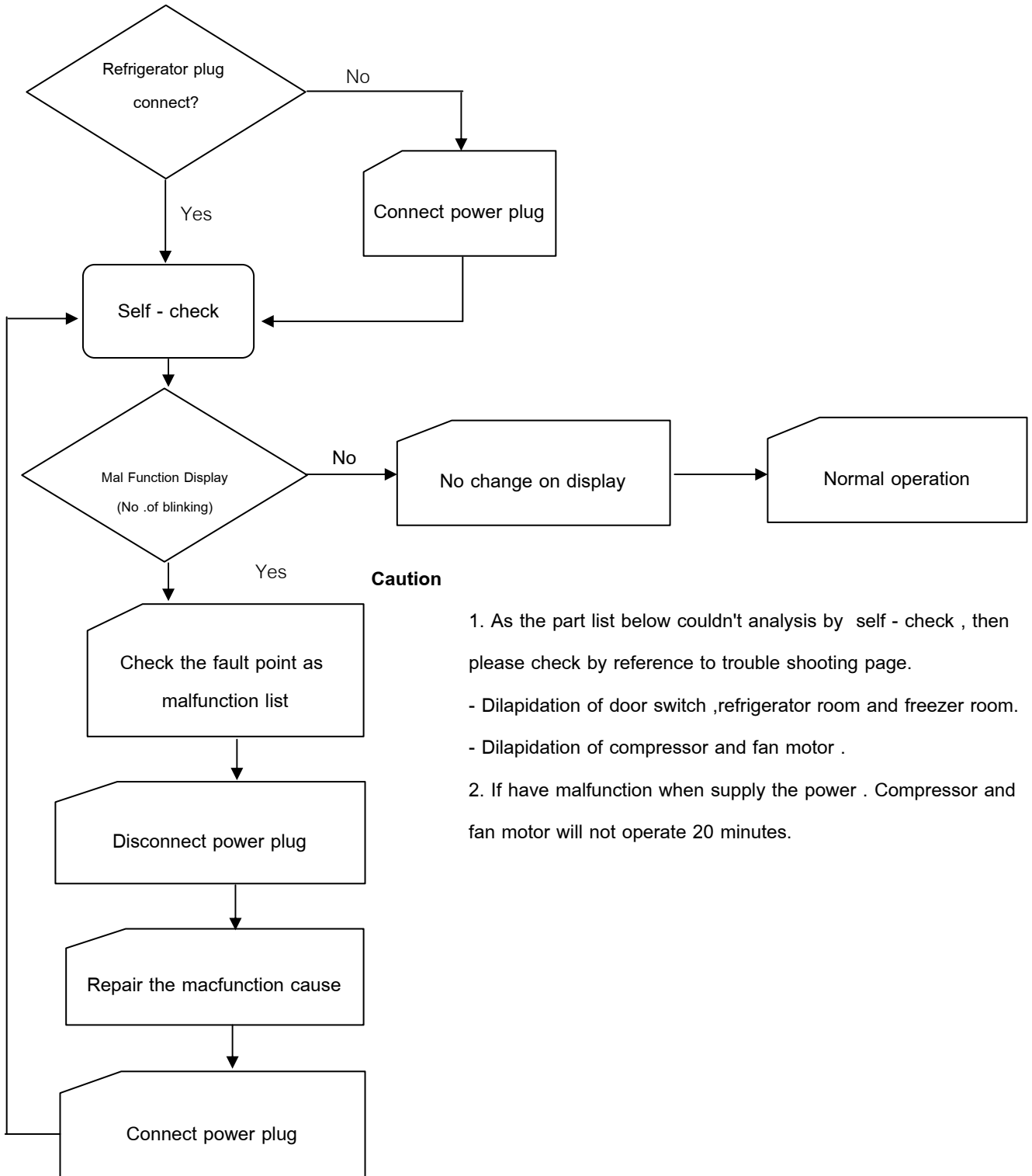

2) Interval of self check analysis

- Troubles of thermistor : will check always.
 - Trouble of defrost heater : will just analyse during defrost display only.
- (The period checking will analyse the defrost circuit after connect the plug 2 hours)

7

DISASSEMBLY INSTRUCTIONS

MR-BF290B-A

MR-BF325B-A

MR-BF390B-A

Plug out before work.

Check the automatic ice-maker by pressing ice making stop switch.

In assembling & disassembling parts use several kind of Screw and Rivet. Do not mistake to use them.

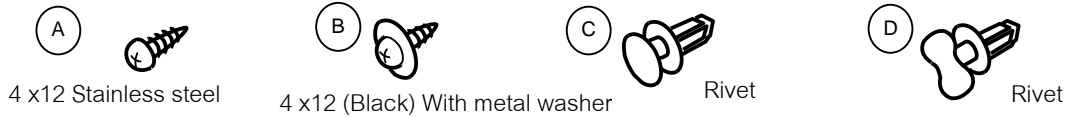

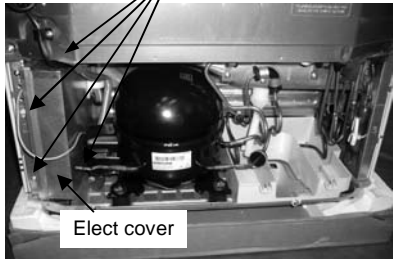
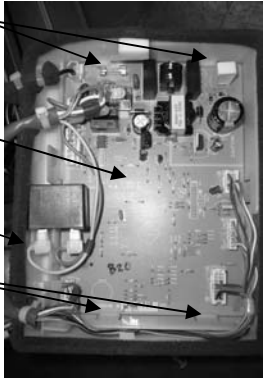
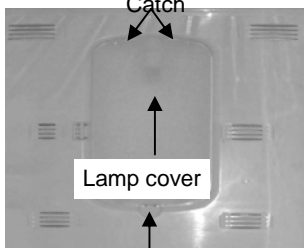
OPERATING PROCEDURE	PHOTOS
<p>1. Detachment Control PCB parts</p> <p>Elect cover</p> <p>(1) Detach 4 pcs. of Elect cover screws. (Photo 1)</p> <p>Elect attach</p> <p>(2) Disconnect the connector and remove Elect attach. (Photo 2)</p> <p>PCB (Refcon assy)</p> <p>(3) Remove the catch of elect attach to release the PCB plate.</p> <p>(Photo 2)</p> <p>Caution on assembly</p> <p>[1] Firmly connect the lead wire and the connector. Ensure the wire are not pinched.</p> <p>[2] Please use the new material of sealing insulation when re-attach.</p>	<p>Photo 1</p> <p>4 fixing screws</p>  <p>Elect cover</p> <p>Photo 2</p>  <p>Catch</p> <p>PCB</p> <p>Elect attach</p> <p>Catch</p>
<p>2. Detachment Lamp cover parts</p> <p>(1) Remove parts inside the refrigerator Shelf 1,2,3 shelf</p> <p>Lamp cover inside the refrigerator</p> <p>(1) Push up the lower catch, and pull the room light cover toward you.</p> <p>(2) Detach two upper catches to take out the cover (Photo 3)</p>	<p>Photo 3</p>  <p>Catch</p> <p>Lamp cover</p> <p>Catch</p>

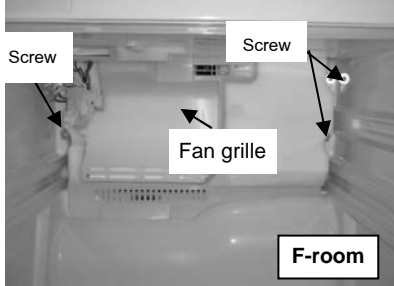
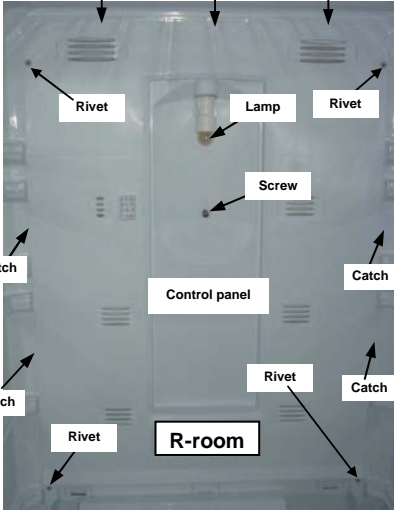

OPERATING PROCEDURE	PHOTOS
<p>4. Detach the refrigerator room parts</p> <p>(1) Detach parts inside the refrigerator compartment.</p> <p>(2) Detach parts inside the vegetable compartment.</p> <p>(3) Detach a left screw of mirror hinge and pull out the lead wire. (Photo 5)</p> <p>(4) Detach the connector.</p> <p>Control panel , Duct R, Temperature control panel</p> <p>(5) Remove the upper and lower rivets (C) of right side and left side, then unhook 7 catches.</p> <p>* Remove the right catch before push the control panel to the right and detach it. (Photo 5)</p> <p>Fan grille</p> <p>(6) Remove the following; Screw (A) at the upper and right center, 2 screws (B) at the left and 2 screws (B) at the right. (Photo 4)</p> <p>* Motor damper and thermal fuse are combined with fan grille.</p> <p>* Fan and fan motor are combined with fan grille.</p> <p>Caution on assembly</p> <p>[1] Use new tapes and sealing materials for assembly.</p> <p>[2] Putting some tape across joints, tape them securely so that they will not leak the cool air.</p> <p>[3] Attach a connector securely in order to prevent contact failure.</p>	<p>Photo 4</p>  <p>Photo 5</p> 

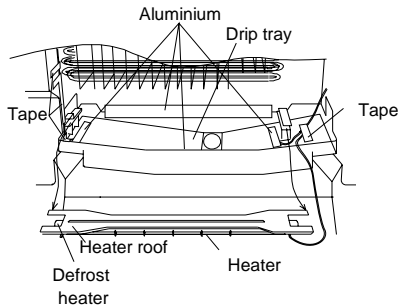
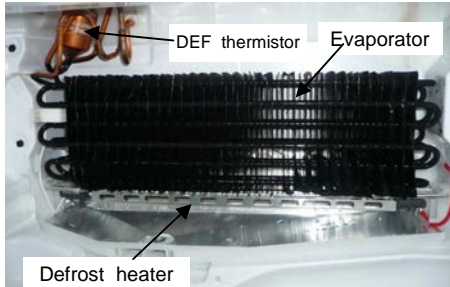

OPERATING PROCEDURE	PHOTOS
<p>Defrost heater, Drip tray</p> <p>(7) Peel off the tape that fixes lead wires on the side wall of the vegetable compartment. Then take out defrost heater together with heater roof.</p> <p>Detach heater roof and Heater cover from Defrost heater.</p> <p>Detach the drip tray after removing the defrost heater.</p> <p>Defrost thermistor</p> <p>(8) Cut the binder and disconnect the connector. (Photo 9)</p> <p>Caution on assembly</p> <p>[1] Loosen the lead wire at the defrost heater to prevent water from entering the glass tube and careful the direction for the correct assembly.</p> <p>[2] Attach the drip tray securely to the lower parts.</p> <p>[3] Attach the defrost thermistor in the correct place. (If they're attached out of place, thermal characteristics will go wrong).</p> <p>[4] Attach the lead wires to the fixture.</p>	<p>Photo 6</p>  <p>Photo 7</p> 

OPERATING PROCEDURE

5 Detachment compressor.

- (1) Collect gas from the charge pipe on the high pressure side.
- (2) After collecting gas, cut the charge pipe on the low pressure side.
- (3) Detach the welded section of the discharge pipe and suction pipe.
- (4) Replace the compressor and the dryer at a time.

Caution on assembly

- (1) After attaching the compressor, must to Vacuum and charge gas from charge pipe.
- (2) Arrange the piping so that the pipe will not hit each other and compressor cover, (which causes loud noise). Then attach the compressor cover.
- (3) After all the work is complete, be sure to check the cooling performance and the gas leak from the welded points.

Attach U washer as the figure shown below

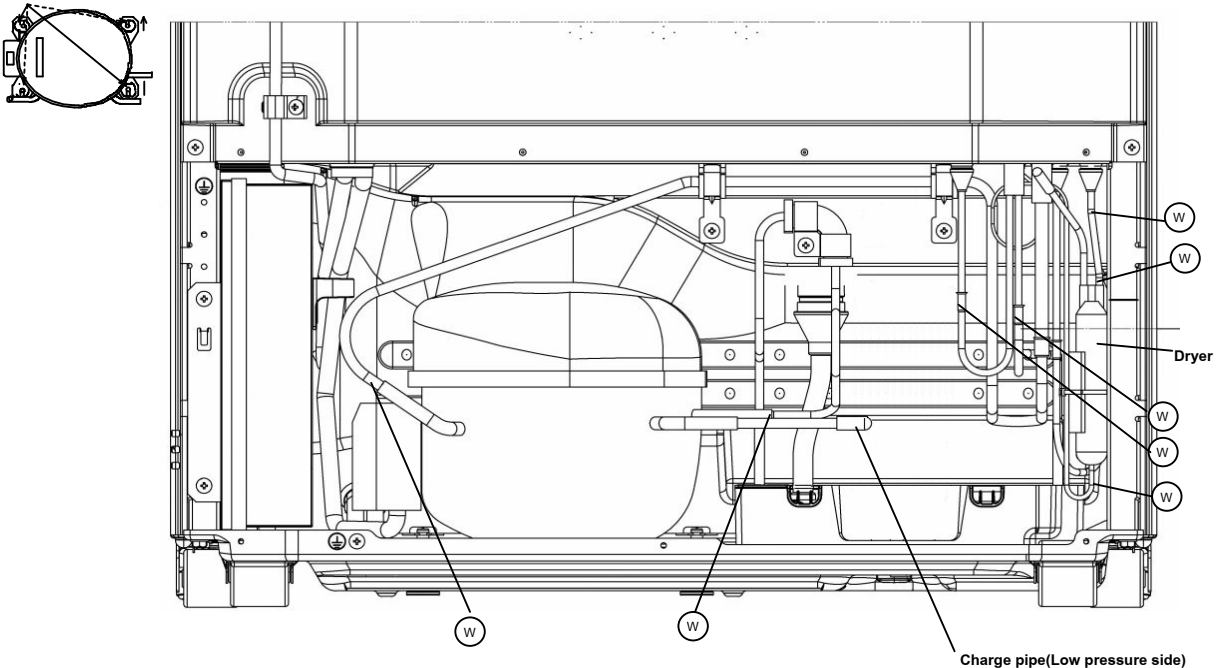

W : This mark shown welded point

DOOR, BODY PARTS

MR-BF290B-A

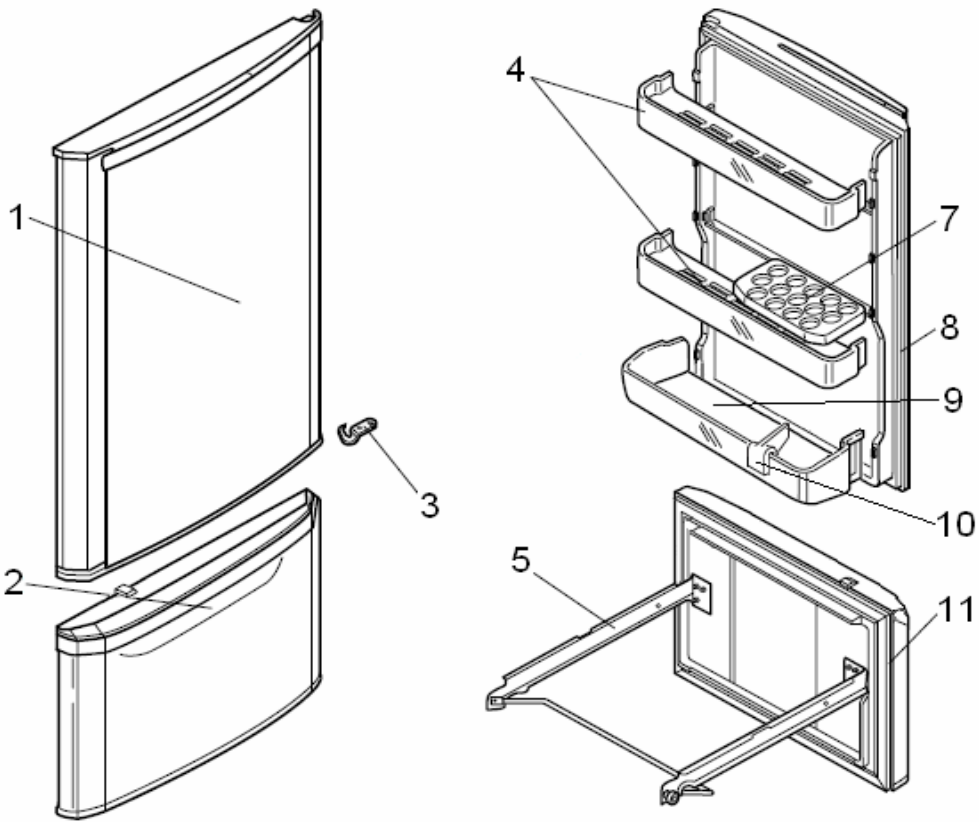

MR-BF325B-A

MR-BF390B-A

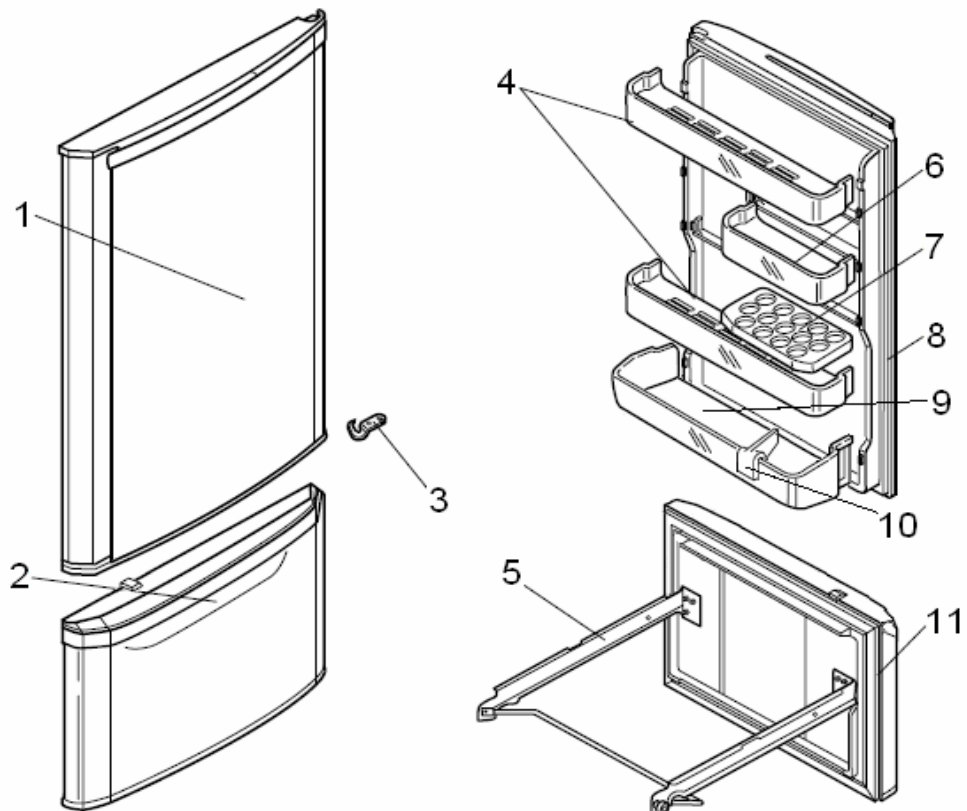

DOOR , BODY PARTS

NO.	PART NO.	RoHS	PART NAME	SPEC	Q'TY/UNIT						PRICE/PIECE(US\$-FOB)	EXPIRY
					MR-BF290B-A		MR-BF325B-A		MR-BF390B-A			
					W	ST	W	ST	W	ST		
1	KIEPE2000	<G>	DOOR R		1							2013
	KIEP91000	<G>				1						2013
	KIEPE7000	<G>					1					2013
	KIEP96000	<G>						1				2013
	KIEPD2000	<G>							1			2013
	KIEP81000	<G>								1		2013
2	KIEPE2001	<G>	DOOR F		1		1		1			2013
	KIEP91001	<G>				1		1		1		2013
3	KIEG05741	<G>	CATCHER RH		1	1	1	1	1	1		2013
4	KIEP89118	<G>	FREE POCKET L		2	2	2	2	2	2		2013
5	KIEP89157	<G>	FRAME F ASSY		1	1	1	1	1	1		2013
6	KIEP89119	<G>	FREE POCKET S				1	1	1	1		2013
7	KIEHJ3115	<G>	EGG CASE		1	1	1	1	1	1		2013
8	KIEP89110	<G>	MAGNET GASKET ASSY (R		1	1						2015
	KIEP94110	<G>					1	1				2015
	KIEP80110	<G>							1	1		2015
9	KIEP80124	<G>	BOTTLE POCKET		1	1	1	1	2	2		2013
10	KIEF13143	<G>	BOTTLE STOPPER		1	1	1	1	1	1		2013
11	KIEP89111	<G>	MAGNET GASKET ASSY (F)		1	1	1	1	1	1		2015
⑫	KIEM92031	<G>	BADGE ASSY		1		1		1			2013
	KIEM64031	<G>				1		1		1		2013

RECOMMEND PART NO. 1, 2, 8, 11

ABBREVIATION

F	FREEZER ROOM
R	REFRIGERATOR ROOM

ENCIRCLED PART NUMBER ARE NOT SHOWN IN THE FIGURES.

Remark

- Country code : A= Australia and New Zealand
- Colour code : W = White, ST = Stainless

BODY PARTS

MR-BF290B-A

MR-BF325B-A

MR-BF390B-A

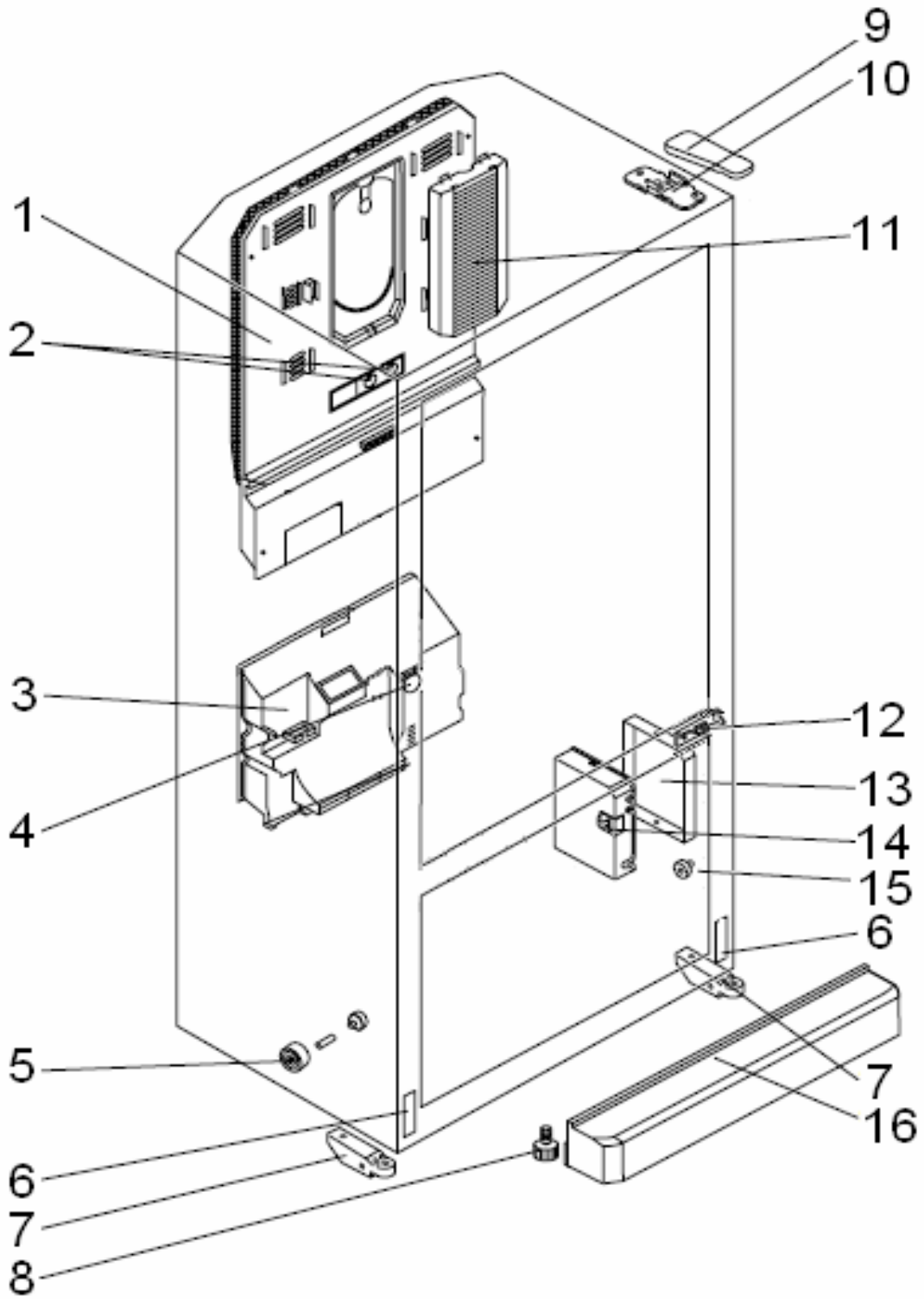

NO.	PART NO.	RoHS	PART NAME	SPEC	Q'TY/UNIT						PRICE/PIECE (US\$-FOB)	EXPIRY
					MR-BF290B-A		MR-BF325B-A		MR-BF390B-A			
					W	ST	W	ST	W	ST		
1	KIEP67858	<G>	CONTROL PANEL		1	1						2013
	KIEP72858	<G>				1	1					2013
	KIEP80858	<G>						1	1			2013
2	KIEHJ3305	<G>	THERMO DIAL (R)		2	2	2	2	2	2		2015
3	KIEPJ2663	<G>	FAN GRILLE ASSY		1	1	1	1	1	1		2015
4	KIEHJ3708	<G>	LABEL FC		1		1		1			2013
	KIEP91708	<G>				1		1		1		2013
5	KIE805794	<G>	CASTER SET		2	2	2	2	2	2		2013
6	KIEHJ3709	<G>	SCREW LABEL (F)		2	2	2	2	2	2		2013
7	KIEH79795	<G>	CASTER ASSY		2	2	2	2	2	2		2013
8	KIEC02460	<G>	ADJUST BOLT		2	2	2	2	2	2		2013
9	KIEP89705	<G>	HINGE COVER		1		1		1			2013
	KIEP91705	<G>				1		1		1		2013
10	KIEP89701	<G>	HINGE ASSY (UP)		1	1	1	1	1	1		2013
11	KIEP89470	<G>	LAMP COVER		1	1	1	1	1	1		2013
12	KIEMT0702	<G>	HINGE ASSY (LOW)		1	1	1	1	1	1		2013
13	KIEP89328	<G>	ELECT BOX COVER ASSY		1	1	1	1	1	1		2013
14	KIEP89326	<G>	ELECT BOX SUB ASSY		1	1	1	1	1	1		2013
15	KIEHJ3798	<G>	ROLLER		2	2	2	2	2	2		2013
16	KIEPE2730	<G>	KICK PLATE		1		1		1			2013
	KIEP91730	<G>				1		1		1		2013
17	KIEPJ5663	<G>	FAN GRILLE		1	1	1	1	1	1		2015
18	KIEP94662	<G>	BELL MOUTH		1	1	1	1	1	1		2015
19	KIEHJ4682	<G>	DUCT DAMPER		1	1	1	1	1	1		2015
20	KIEP80336	<G>	THERMAL FUSE ASSY		1	1	1	1	1	1		2015

RECOMMEND PART NO. 3, 20

ABBREVIATION

F	FREEZER ROOM
R	REFRIGERATOR ROOM

ENCIRCLED PART NUMBER ARE NOT SHOWN IN THE FIGURES.

ELECTRICAL PARTS

MR-BF290B-A

MR-BF325B-A

MR-BF390B-A

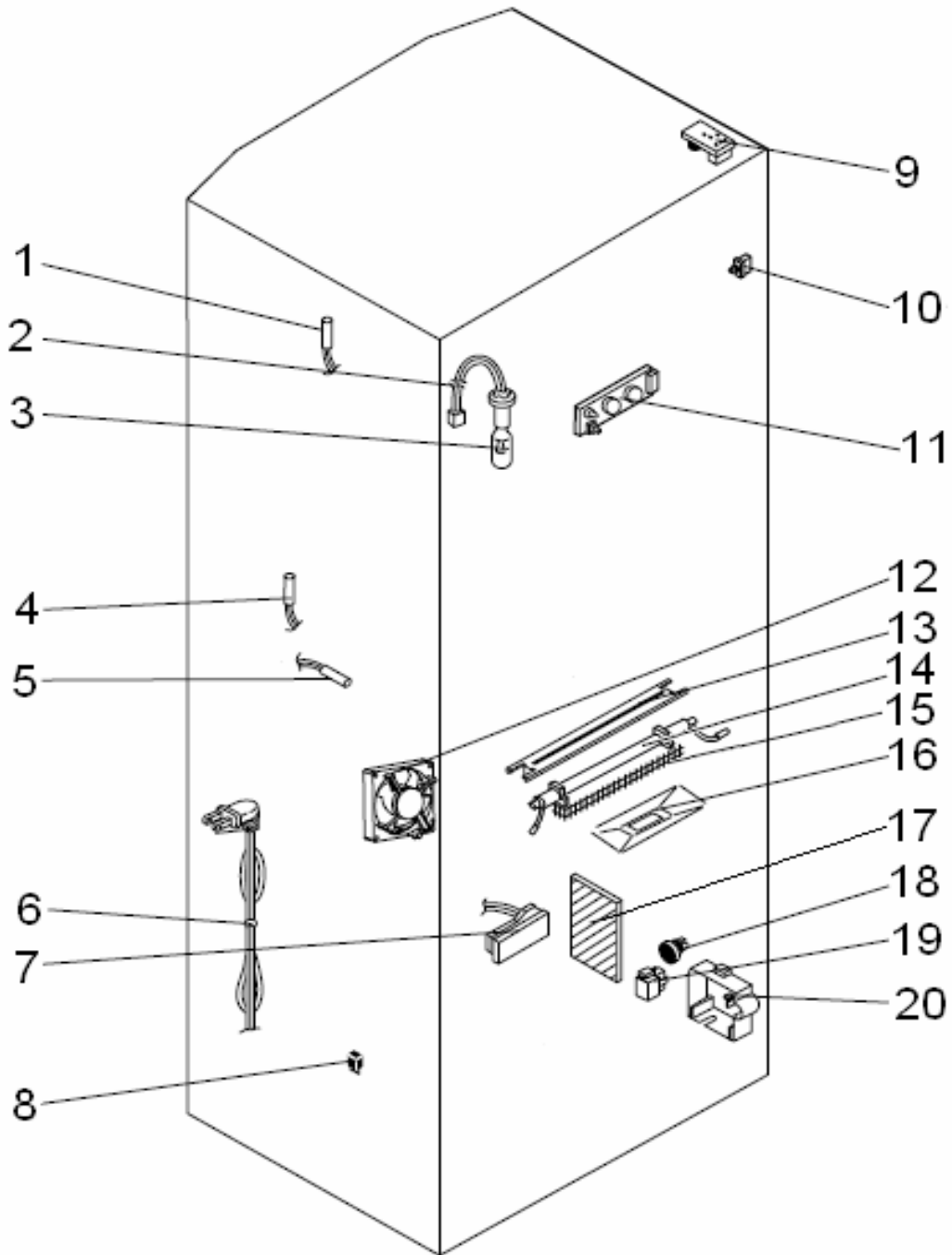

NO.	PART NO.	RoHS	PART NAME	SPEC	Q'TY/UNIT						PRICE/PIECE (US\$-FOB)	EXPIRY
					MR-BF290B-A		MR-BF325B-A		MR-BF390B-A			
					W	ST	W	ST	W	ST		
1	KIEHJ3313	<G>	THERMISTOR (R)		1	1	1	1	1	1		2015
2	KIEP89386	<G>	LAMP SOCKET		1	1						2015
	KIEP94386	<G>				1	1					2015
	KIEP80386	<G>						1	1			2015
3	KIE402360	<G>	LAMP	240V 15W E12	1	1	1	1	1	1		2015
4	KIEP89312	<G>	THERMISTOR (DEF)		1	1	1	1	1	1		2015
5	KIEP80378	<G>	THERMISTOR (F)		1	1	1	1	1	1		2015
6	KIEPE2354	<G>	PLUG CORD ASSY		1	1	1	1	1	1		2015
7	KIEHJ3362	<G>	REED SWITCH		1	1	1	1	1	1		2015
8	KIELR4346	<G>	RUNNING CAPACITOR	4μF 400VAC	1	1	1	1	1	1		2015
9	KIEKA0374	<G>	BUZZER BOARD & THERMISTOR (A.T.)		1	1	1	1	1	1		2015
10	KIEMQ4363	<G>	LAMP SWITCH (R)		1	1	1	1	1	1		2015
11	KIEKA0382	<G>	TEMP CONTROL PANEL		1	1	1	1	1	1		2015
12	KIEMQ4320	<G>	FAN MOTOR ASSY		1	1	1	1	1	1		2015
13	KIEP89537	<G>	HEATER ROOF		1	1	1	1	1	1		2015
14	KIEP89392	<G>	DEFROST HEATER		1	1	1	1	1	1		2015
15	KIEP89397	<G>	HEATER COVER		1	1	1	1	1	1		2015
16	KIEP89538	<G>	DRIP TRAY		1	1	1	1	1	1		2015
17	KIEPC4339	<G>	REFCON ASSY		1	1						2015
	KIEPC6339	<G>				1	1					2015
	KIEPD2339	<G>						1	1			2015
18	KIEMR7340	<G>	MOTOR PROTECTOR	5TM222NFBYY	1	1	1	1	1	1		2015
19	KIEE76330	<G>	PTC RELAY	PTH7M330MD2	1	1	1	1	1	1		2015
20	KIEG05341	<G>	PROTECTOR COVER		1	1	1	1	1	1		2013

RECOMMEND PART NO. 1, 3, 4, 5, 9, 11, 14, 17, 18, 19

ACCESSORY AND UNIT PARTS

MR-BF290B-A

MR-BF325B-A

MR-BF390B-A

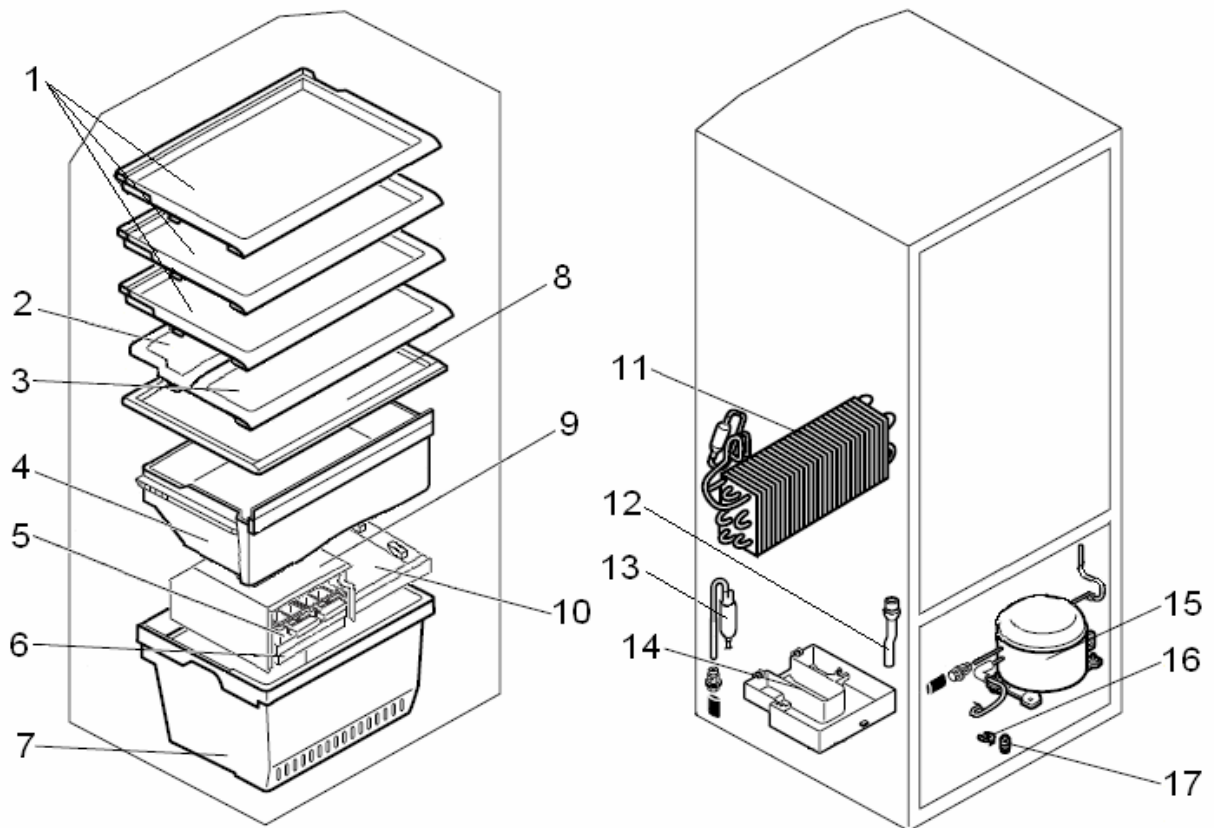

NO.	PART NO.	RoHS	PART NAME	SPEC	QTY/UNIT						PRICE/PIECE (US\$-FOB)	EXPIRY
					MR-BF290B-A		MR-BF325B-A		MR-BF390B-A			
					W	ST	W	ST	W	ST		
1	KIEP89420	<G>	GLASS SHELF R ASSY		1	1	2	2	3	3		2013
2	KIEP80427	<G>	GLASS SHELF REAR ASSY		1	1	1	1	1	1		2013
3	KIEP80428	<G>	GLASS SHELF FRONT ASSY		1	1	1	1	1	1		2013
4	KIEP80413	<G>	UTILITY CASE		1	1	1	1	1	1		2013
5	KIEL55440	<G>	ICE TRAY		1	1	1	1	1	1		2013
6	KIEG63487	<G>	ICE BOX		1	1	1	1	1	1		2013
7	KIEP89475	<G>	F CASE (LOW)		1	1	1	1	1	1		2013
8	KIEP89420	<G>	GLASS SHELF R ASSY		1	1	1	1	1	1		2013
9	KIEP80450	<G>	ICE CORNER		1	1	1	1	1	1		2013
10	KIEP80431	<G>	TRAY F		1	1	1	1	1	1		2013
11	KIEP89995	<G>	EVAPORATOR		1	1	1	1	1	1		2015
12	KIEP89504	<G>	ELBOW		1	1	1	1	1	1		2013
13	KIEAA1980	<G>	DRYER	4AXH-9,10GR	1	1	1	1	1	1		2015
14	KIEP89435	<G>	DRAIN PAN		1	1	1	1	1	1		2015
15	KIEPE2277	<G>	COMPRESSOR	DHS66C10RAW	1	1	1	1	1	1		2015
16	KIEHJ3735	<G>	U WASHER		4	4	4	4	4	4		2013
17	KIEE76797	<G>	RUBBER MOUTH		4	4	4	4	4	4		2013

RECOMMEND PART NO. 1, 2, 3, 4, 11, 13, 15

PACKING PARTS

MR-BF290B-A

MR-BF325B-A

MR-BF390B-A

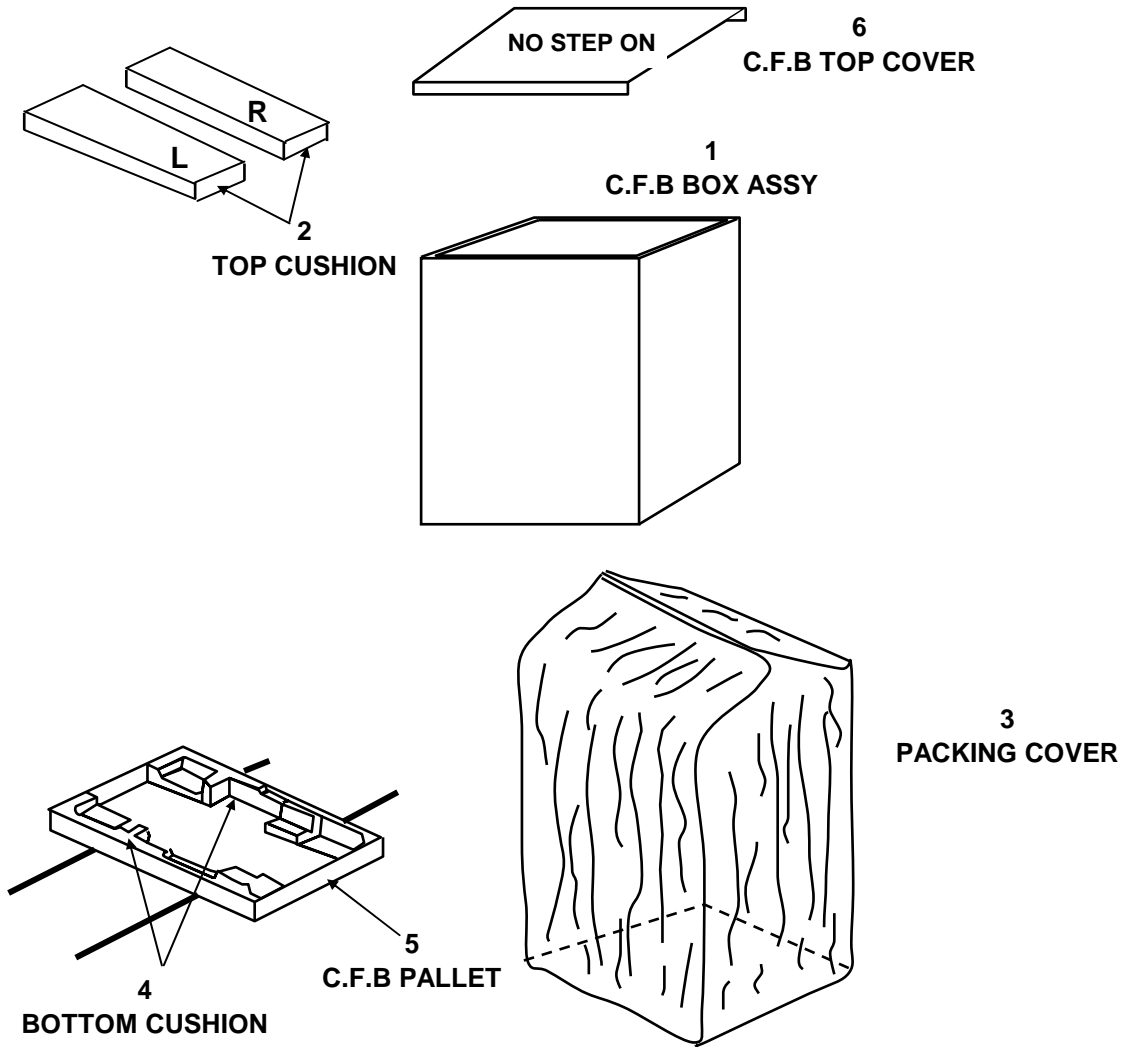

NO.	PART NO.	RoHS	PART NAME	SPEC	Q'TY/UNIT						PRICE/PIECE (US\$-FOB)	EXPIRY
					MR-BF290B-A		MR-BF325B-A		MR-BF390B-A			
					W	ST	W	ST	W	ST		
1	KIEPC4970	<G>	C.F.B BOX ASSY		1							2011
	KIEPC5970	<G>				1						2011
	KIEPC6970	<G>					1					2011
	KIEPC7970	<G>						1				2011
	KIEPD2970	<G>							1			2011
	KIEPD3970	<G>								1		2011
2	KIEP89979	<G>	TOP CUSHION		1	1	1	1	1	1		2011
3	KIEHJ3973	<G>	PACKING COVER		1	1	1	1	1	1		2011
4	KIEP89978	<G>	BOTTOM CUSHION		1	1	1	1	1	1		2011
5	KIEP89974	<G>	C.F.B PALLET		1	1	1	1	1	1		2011
6	KIEP89975	<G>	C.F.B TOP COVER		1	1	1	1	1	1		2011



MITSUBISHI ELECTRIC CORPORATION

HEAD OFFICE : MITSUBISHI DENKI BLDG., MARUNOUCHI, TOKYO 100. TELEX : J24532 CABLE MELCO TOKYO

Distributed by

MITSUBISHI ELECTRIC AUSTRALIA PTY LTD.

(Incorporated in New South Wales) ABN 58 001 215 792

New South Wales :
348 Victoria Road,
Rydalmere NSW 2116
Ph : (02) 9684 7777
Fax : (02) 9898 1043

Queensland:
Unit 12, 469
Nudgee Road,
Hendra QLD , 4011
Ph : (07) 3263 2000
Fax : (07) 3630 1888

South Australia /
Northern territory :
77 Port Road
Hindmarsh SA 5007
Ph: (08) 8340 2000
Fax : (08) 8340 0555

Western Australia :
329 Collier Road,
Bassendean WA 6054
Ph : (08) 9377 3400
Fax : (08) 9377 3499

Victoria / Tasmania :
Building 28, Omnico bus. Park
270 Ferntree Gully Road,
Notting Hill 3168
Ph : (03) 9535 7800
Fax : (03) 9535 7801

Far North
Queensland:
Capricorn Air,
13 Mackley St,
Garbutt 4814
Ph: (07) 4775 5222
Fax : (07) 4775 5303

Distributed by

BLACK DIAMOND TECHNOLOGIES LIMITED (BDT)

Wellington Office (Head Office)
1 Parliament Street
PO Box 30-772
Lower Hutt
Ph : (04) 560 9100
Fax : (04) 560 9133

Auckland Office
Unit1, 4 Walls Road
Penrose
Auckland PO Box 12-726
Ph: (09) 526 9340
Fax : (09) 526 9369

Christchurch Office
Suite 2, Level 1
37 Manderville Street
Christchurch PO Box 1604
Ph : (03) 341 7052
Fax : (03) 341 7054