

The leader in multi drawer refrigeration.



Versatile

Sienna



MR-G50J-SS

STAINLESS

- Surround Multi Air-Flow
- Moist Radiant Cooling
- Frost and CFC Free
- Anti-bacterial Deodoriser
- Door Alarm System
- Mirror LCD Panel with Neuro Fuzzy Logic
- Energy Efficient
- Silent Operation
- Three-way Flexishelf
- Two-way Flexishelf
- Height Adjustable Shelf
- Wide Chilled Egg Case
- Sliding Chilled Case
- Side-take-out Bottle Pocket with Tube stand
- Automatic Door Closer
- Automatic Ice Maker
- Independent Ice Tray Drawer
- Crystal Clear Ice Making
- Rapid Ice Making
- Silent Ice Making
- Freezer Drawer with extra Sliding Tray
- Vitamin Factory
- Vegetable Drawer
- Versa Drawer with Aluminium Tray
- Soft Freezing
- Quick & Standard Chill
- Quick Freezing (8x faster)

Benefit of the centre split door

The G50 features a split door refrigerator compartment. The reduced width of each door minimises the space used when open, unlike traditional single door fridges.

No partition means more space

There is no partition in the refrigerator, so wide sized food items, such as platters are easily accommodated.

User-Friendly Design

The location of the refrigerator compartments has traditionally been designed according to temperature requirements rather than by how often each compartment is used. The Sienna Collection is designed to provide the easiest access to those areas that are most often used.

Mirror LCD Panel

The Mirror LCD display panel lights up when buttons are pressed. Temperature settings, quick cooling, etc. for each compartment can be controlled without opening the refrigerator door. When not in use the panel becomes a half-mirror display.

Universal Layout

Performance and function making your life easier.

Flexible Shelves - Adjust the shelves and door pockets to match the size of your food containers.

2-Way Flexishelf

Adjustable Door Pocket

Height Adjustable Shelf

3-Way Flexishelf

Side-take-out Pocket
Now you can easily remove items from the side of the door pocket.

Automatic Ice Maker with built-in Water Tank
Water is purified with the power of light. Removes lead and chlorine from tap water and kills bacteria with UV light while automatically making Crystal Ice.

Sliding Chilled Case

Tube Stand

Independent Ice Tray Drawer
The ice drawer is now separated from freezer, keeping the ice clean and fresh from odours that are usually found in a freezer compartment.

Versa Drawer

- Quick & standard chill.
- Soft freezing.
- Quick freezing (8x faster).
- Increase freezer space by switching the versa drawer to a freezer compartment.

Wide Chilled Egg Case and Multi-purpose Drawer

- The Wide Chilled Egg case is four times better at preserving the freshness of your eggs, and can be removed to allow taller storage.
- The Multi-purpose Drawer is perfect for storing dairy, fish and meats.
- A unique Anti-bacterial Deodoriser will keep these drawers smelling fresh.

Easy Access Vegetable Drawer

- It opens 100% to enable easy access.
- Moist radiant cooling from three sides of the case keep your vegetables chilled without direct contact to the cooling air. It keeps a high level of 90% humidity all the time.
- Ultraviolet LED Emitting Vitamin Factory Vegetable Compartment.

Freezer Drawer
Food is very easy to organise with this large capacity freezer drawer and its extra slide out tray.

Automatic Ice Maker



Crystal Clear Ice

Clean clear ice made from water that is purified by the power of light. Ice is slowly made to improve the transparency.



Crystal Ice

Normal Ice

Rapid Ice Making

-40°C Rapid Ice Making. If you are in a hurry, 60 to 100 pieces of ice can be made within an hour, continuing in this mode for up to 8 to 9 hours.



Silent Ice Making

The silent mat absorbs the sound of the ice dropping down in the ice drawer.



Kills bacteria with the power of light

The light emitted by the V-LED decreases lead elements, chlorine and other germs leaving delicious pure water.

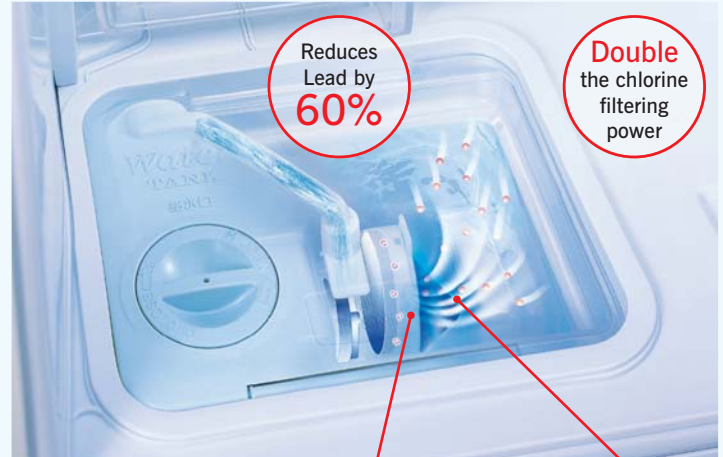

VU Catalyst and Lead-reducing Filter

V-LED



Mineral water can be used

Easy to check the water amount



Completely Washable

Fully removable parts make for easy cleaning of the ice maker. The ice tray is conveniently located under the water tank, therefore the water pipe is short and prevents dirt from accumulating.

Easy to wash pipes



Easy tank removal



Removable parts for hygiene



Versa Drawer



Use the Versa Drawer for

Standard Freeze

Extra freezer space when the bottom freezer is full.

Soft Freeze

Soft freezing with -7°C

For preserving meats and fish for 2-3 weeks.

It is able to alternate between 3 temperature stages.

Quick Freeze

8 times faster, freezes food instantaneously by -40°C cooling air, and preserves the good taste of food.

Standard Chill

Chilled preservation

Processed food including hummus and yogurt, cheese etc. can be preserved for about one week.

Quick Chill

When unexpected guests come, there is a space to quickly chill drinks, food or veges.

Soft Freezing

Just cut what you need. No more thawing before cutting, or cutting before freezing.

Foods are frozen but kept soft enough to slice with a knife. There is no need to portion your meat before freezing. As you can freeze the foods with its original package, you don't need to rewrap them. It can eliminate the need of thawing, saving your cooking time.

· *Soft Freezing is ideal for food that you will use within two to three weeks.*

· *The temperature of the cooling air has been further decreased to -40°C , instantaneously cooling your food to retain its flavour and taste.*



Cut Easily and Save Time

With Conventional Freezing you need to:

- Separate foods before freezing, wrapping each item individually.
- Wait for food to thaw.

But with Soft Freezing:

- Put various items in without separating them.
- Cut and cook food immediately.

Quick Freeze Comparison

When meat is frozen its water content becomes ice, destroying food cells and deteriorating food taste. However, if it is frozen by **Quick Freezing**, only small ice crystals will be formed so that the taste will not be ruined after defrosting.

Quick Freezing

Conventional Freezing

Drip comparison at defrosting of beef steak meat.

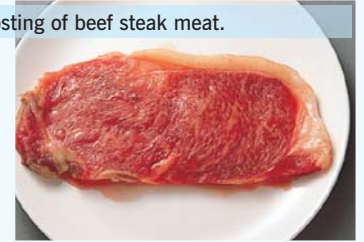

Almost no drips

The flavour disappears

Comparison of beef meat cell tissues.

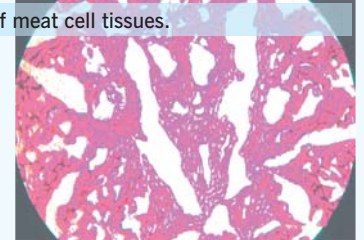
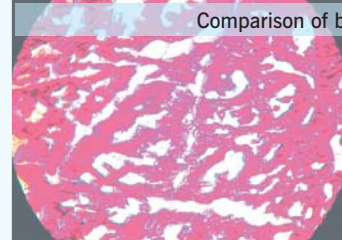

Ice grains are small and retains flavour

Ice grains are big, broken cells and it lacks taste

Soft Freezing

Conventional Freezing

Soft Freezing - No defrosting time



Easy to cut without defrosting

Need to defrost before cooking

Soft Freezing - No portioning is needed



Easy to peel apart

Need to portion food in plastic wrap

Economical

Baby Food

Take as much as you want and save the rest



Sorbet

Fruit sorbet is easy to make

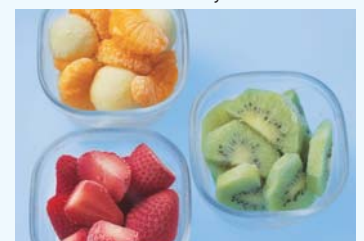

Fresh and Tasty



Surround Multi Air-Flow



Re-cooling 3 times faster.

Surround Multi Air-Flow restores the temperature three times faster after the doors have been opened than previous models.

Food stays fresher for longer as the 6 temperature regulation points in the refrigerator ensure uniform cooling and airflow to all shelves at a high level (60 -80%) of humidity.

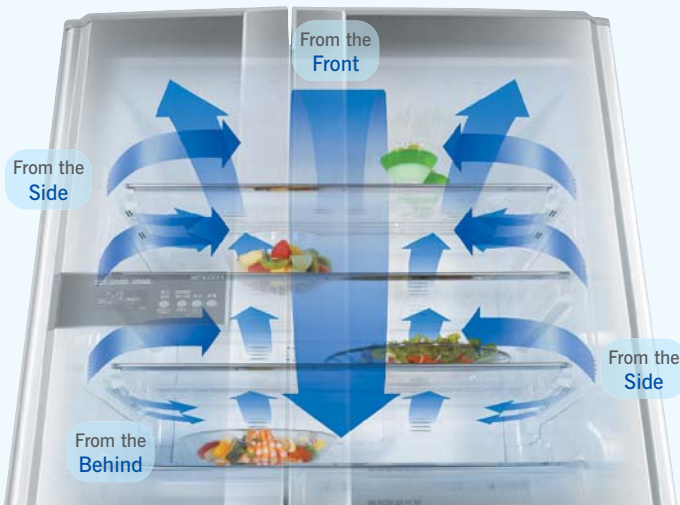

Cold air is emitted not only from behind but also from the both sides and the front. Therefore, the entire room is cooled quickly and uniformly.

Door pockets are also cooled.

Efficiently cools all food, even in hard-to-cool places such as filled door pockets.

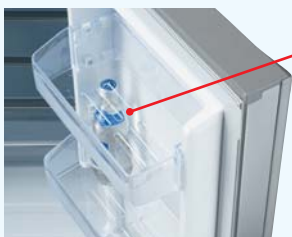

The cold air circulates from the gaps in the bottom of the shelf, cooling the pocket areas quickly.



Temperature distribution.

Conventional Refrigerator

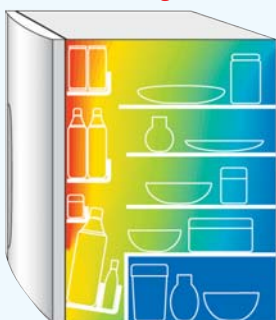

G50 Multi Air-Flow Refrigerator



The Secret To Humidity Control

Moist Radiant Cooling in Vegetable Drawer.

Moist radiant cooling from three sides of the case keep your vegetables cooled without actual direct contact with the cooling air. It keeps a high level of 90% humidity all the time.

Conventional Model



2.5 days of storage

Light-powered Crisper



2.5 days of storage



Thermo Sensor

Vitamin Factory Vegetable Drawer



How it works:

The new revolutionary vegetable compartment stimulates the self-defence function of vegetables by means of two LED (ultra-violet) lights that are mounted on the back and bottom of the vegetable compartment.

What it does:

Antioxidants in vegetables increased by 10% compared to the time of purchase, and the amount of retained antioxidant content can be up to 1.2 times more than that of the vegetables preserved in prior refrigerators without light radiation. Simply put, vegetables stay fresh and healthy for longer!

About 1.5 times more Vitamin C

The Vitamin C level increased about 10% in three days when storing Broccoli, while the previous models lost 25%.

About 1.2 times more Antioxidants

The Antioxidants level increased about 10% in three days when storing Cress, while the previous models lost 10%.

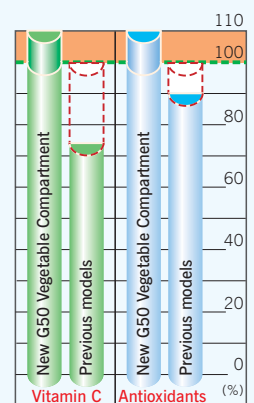

Healthy, Clean & Efficient



Efficient Cooling

Because it is able to send cold air only into a compartment when needing to be cooled, power consumption is minimal, therefore conserving energy.

With non-dampened models you would get uneven airflow.

Now with the new Mitsubishi Cycling Loss Saving System airflow is regulated by dampers. This allows even air flow to all areas or fast cooling by allowing 100% to a specific area like the Versa Drawer.

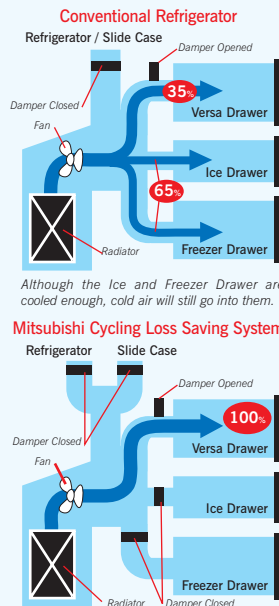

6 Sensors

These sensors monitor each area. Temperatures can be changed using the LCD panel.

1. The 6 sensors monitor temperature change.
2. If change occurs cold air is sent into the area that needs to be cooled, by using the dampers which regulate the air flow.
3. An additional source of powerful cold air can be sent to the area as well.

Resulting in a quick return to the set temperature.

- Refrigerator Compartment
- Slide Compartment
- Versa Drawer
- Ice Drawer
- Vegetable Drawer
- Freezer Drawer

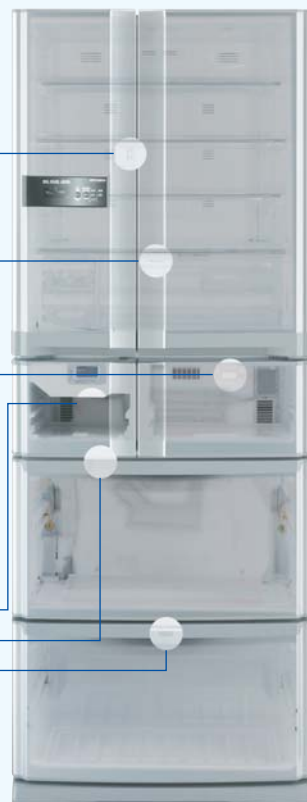

Anti-bacterial Deodoriser

A world-first in home refrigeration. Odour-causing agents and contaminants are broken down into carbon dioxide and water. Bacteria is trapped in the filter and destroyed by anti-bacterial agents.

Mitsubishi Electric's exclusive all compartment deodoriser powerfully deodorises not just the refrigerator compartment, but the whole of the fridge including the ice box and freezer compartments.

Anti-oxidation means double the fresh air. Freshly cooled air with a deodorising, anti-bacterial effect powerfully cools down every space in the refrigerator.

Oxidation Decreased by rate of 40%

Suppress the oxidation of food and preserve freshness

The cooling air passed through the double fresh filter both removes bacteria and deodorises.

This means, the oxidation of food is decreased. Your food stays fresher longer, and bad smells are reduced.

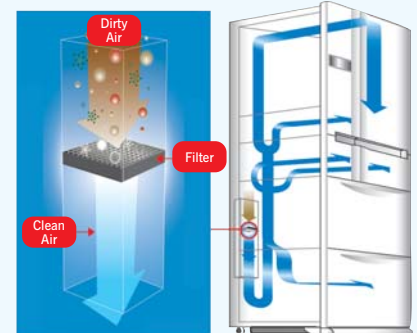

Energy Efficient

Introducing Mitsubishi Electric's unique inverter technology. The Digital control with a compressor is more precise than our previous models. Smooth operation is assured. The result is low energy consumption and quiet operation.

Save Mode.

When your family is away from home, the Save Mode adjusts the settings of the refrigerator for greater energy efficiency.

Neuro Fuzzy.

The refrigerator remembers and learns how you use it for a weekly period. The Neuro Fuzzy control produces optimal settings. The microcomputer adjusts to your lifestyle pattern, and conserves energy by avoiding wasteful refrigeration thus lowering your electricity bills.

Door Alarm System



If the door of a compartment is left open for over a minute, the Door Alarm sounds to inform you that the door needs to be closed. This is to prevent the temperature inside the refrigerator rising to a level where food can spoil.

Silent Operation

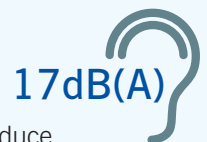

Technological advances have allowed us to reduce noise levels by more than 80%, from 25 to 17dB(A)*.

**Compared to similar Mitsubishi refrigerators produced ten years ago, when operating in silent mode.*

Automatic Door Closer

For the first time in the industry, the doors of the refrigerator compartments will close automatically when the doors are half closed*.

**The angle between the body and the door is less than 20°.*

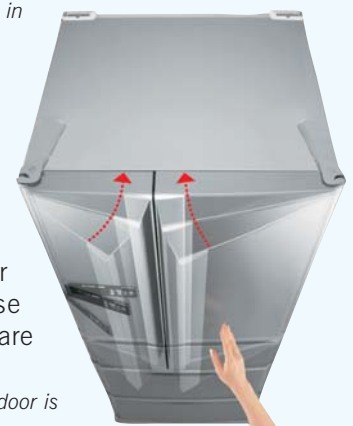

Specifications

		Model	MR-G50J-SS
Capacity (litres)	Total	Net	404
		Gross	540
	Refrigerator Room	Net	252
		Gross	272
	Ice Room	Net	7
		Gross	20
	Versa Room	Net	20
		Gross	47
	Vegetable Room	Net	69
		Gross	116
Freezer Room	Net	56	
	Gross	86	
Dimensions (mm)	Width	745	
	Height	1798	
	Depth	699	
Weight (kg)	Net	99	
	Gross	108	
Energy Star Rating		3.5	
kWh Per Year		660	

Required Space for Installation

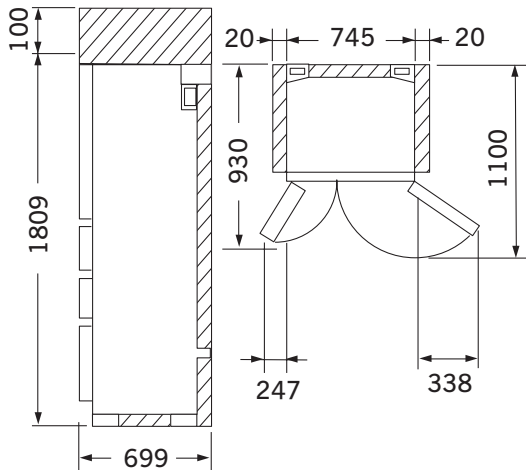

Warranty

2 Years Parts and Labour Warranty, with a 5 Year Compressor Warranty.

Refrigerator Compartment	
Surround Multi Air-Flow	.
Moist Radiant Cooling	.
Automatic Door Closer	.
Side-take-out Pocket	.
Changeable Flexishelf	.
Mirror LCD Panel	.
Sliding Chilled Case	.
Tube stand	.
Multi-purpose Chilled Egg Tray	.
Big Tower Light	.
Vegetable Drawer	
Moist Radiant Cooling	.
Easy Access Vegetable Compartment	.
Vegetable Stand	.
Versa Drawer	
Soft Freezing	.
Multi-Temperature Setting	.
Aluminium Tray	.
Ice Drawer	
Direct Water Supply Auto Ice Maker	.
Built in Water Tank	.
Crystal Ice	.
Silent Ice Making	.
Complete Water Supply Route Washable	.
Ice Tray Cleaning Mode	.
Clean Ice Making by V-LED	.
Reduce Lead Ice Making	.
-40°C Cold Air Quick Ice-Making	.
Easy to check the water amount	.
Big Ice Making	.
Freezer Drawer	
-40°C Cold Air Quick Freezing	.
Easy Access Freezer Compartment	.
Others	
Non CFC Cooling System (Refrigerant)	R600a(Iso-Butane)
Frost Free	.
All Room Deodoriser	Anti-Oxidising Filter
Six Sensors	.
Inverter	.
Neuro Fuzzy	.
Large-sized Radiator	.
Door Alarm	.
Colour	Stainless Steel



AUCKLAND

Unit 1, 4 Walls Road
PO Box 12-726, Penrose
Phone (09) 526 9347, Fax (09) 526 9348

WELLINGTON (HEAD OFFICE)

1 Parliament Street
PO Box 30-772, Lower Hutt
Phone (04) 560 9147, Fax (04) 560 9133

CHRISTCHURCH

Suite 2, Level 1, 37 Mandeville Street
PO Box 1604, Christchurch
Phone (03) 341 2837, Fax (03) 341 2838